

# 440

## Weigh Scale Indicator

### Installation/Calibration/Operation

Version 4.2 10/3/2001  
Program S440012x



Load Cell Central follows a policy of continuous improvement and reserves the right to change specifications without notice. © 2011

Load Cell Central  
216 Main St. / PO Box 91  
Monroeton, PA 18832  
Web: [www.800loadcel.com](http://www.800loadcel.com)

Toll Free: 1-800-562-3235  
Ph: 1-570-265-5015  
Fax: 1-570-265-5148  
Email: [sales@800loadcel.com](mailto:sales@800loadcel.com)

# Table of Contents

<b>Introduction</b> .....	<b>1</b>
What's In Each Section.....	2
WARRANTY INFORMATION .....	3
<b>General Description</b> .....	<b>4</b>
440 Display and Keyboard Diagram .....	4
The 440 Display .....	5
The 440 Keyboard.....	5
Numeric Keypad .....	5
Function Keys .....	5
Control Keys .....	5
<b>Installation and Setup</b> .....	<b>6</b>
Unpacking the 440 .....	6
Item check list.....	6
Installation Guide .....	7
Connect 440 to load cell.....	7
Connect 440 to the printer (optional).....	7
Apply AC Power to the 440 .....	7
Setup Guide .....	9
Initialize to Factory Defaults .....	9
Setup & "Quick" Calibration Guide .....	9
Calibrate the Weight Indicator .....	9
<b>Using the 440</b> .....	<b>10</b>
Keyboard Layout .....	10
Operation of Function Keys .....	10
Zero .....	10
Tare .....	11
Gross/Net.....	11
Print .....	11
F1 and F2 .....	11
Memory Register Entry.....	11
Execute a Scale Basic Function.....	11
Display Time/Date .....	11
<b>Built In Application Programs</b> .....	<b>13</b>
<b>#1 Fill to Setpoint</b> .....	<b>14</b>
Installation .....	14
Setup Parameters: .....	14
Operators Functions.....	14
Enter setpoint.....	14
Start fill operation.....	14
Stop fill operations .....	14
Print Results .....	14
Error Codes .....	14
<b># 2 Checkweigh: Under/Between/Over</b> .....	<b>15</b>

Installation .....	15
Operators Functions.....	15
Enter setpoint weights .....	15
Recalculate .....	15
<b># 3 Weigh-in / Weigh-out.....</b>	<b>16</b>
Weigh-In .....	16
Weigh-Out.....	16
Print ID's, Display ID's, Clear Totals, Erase ID's.....	16
Set Beginning Sequence Number .....	17
Options .....	17
Notes .....	17
<b># 4 Axle Weigh – Short Scale.....</b>	<b>18</b>
Installation .....	18
Setup Parameters .....	18
Operators Functions.....	18
<b># 5 Axle Weigh – Long Scale, Unattended.....</b>	<b>19</b>
Installation .....	19
Setup Parameters .....	19
Operators Functions.....	19
<b># 6 ID, Tare, and Total.....</b>	<b>20</b>
Enter ID Tare Data .....	20
Recall ID and Tare.....	20
Print and Total ID.....	20
Print ID's, Display ID's, Clear Totals, Erase ID's.....	20
Set Beginning Sequence Number .....	21
Notes .....	21
<b># 7 Peak Hold Function.....</b>	<b>21</b>
Enable Peak Hold.....	21
Clear Peak Hold Register .....	21
Display Peak Weight .....	21
Print Peak Weight.....	21
<b>Set Operation Parameters.....</b>	<b>23</b>
Access Operation Parameters and Parameter Functions .....	23
Operation Parameters Reference Tables .....	23
Scale Parameters .....	24
I/O Port Parameters.....	24
Display Intensity, Battery, Watchdog Timer .....	25
Fixed Setpoints.....	25
Keyboard Events .....	25
Parameter Functions .....	26
Scale Parameters.....	27
Parameter 1. Load Cell mv/V (3 mv/v) .....	27
Parameter 2. Digital Filter (9) .....	27
Parameter 3. Display Update Rate (1) .....	27
Parameter 4. Motion Detection Delay (6).....	28
Parameter 5. Motion Detection Band (6).....	28
Parameter 6. Display Blanking During Motion (No Blanking).....	28
Parameter 7. Zero Tracking Delay (0).....	28
Parameter 8. Zero tracking band (12) .....	28
Parameter 9. Push Button Zero Percent (100).....	29

Parameter 10. Primary Units Type (1 [lb]).....	29
Parameter 11. Decimal Point Position (0 [no decimal point]).....	29
Parameter 12. Count-by (1).....	29
Parameter 13. Alternate Units Type (2 [kg]).....	30
Parameter 14. Alternate Decimal Point (1).....	30
Parameter 15. Alternate Count-by (5).....	30
Parameter 16. Alt Units Conversion Factor (45,360).....	30
Parameter 17. Full Scale Graduations (10,000).....	31
Parameter 18. Overload Graduations (10,200).....	31
Parameter 19. Deadload Offset.....	31
Parameter 20. Disable Power-On Zero (1 [disabled]).....	31
Parameter 21. Deadload Factor.....	31
Parameter 22. Weight Conversion Factor.....	31
Serial I/O Ports.....	32
Parameter 23 Serial Port 1 Mode (4 [8 data bits, no parity]).....	32
Parameter 24 Serial Port 1 Baud Rate (1 [9600 baud]).....	32
Parameter 25 Serial Port 2 Mode (4 [8 data bits, no parity]).....	33
Parameter 26 Serial Port 2 Baud Rate (1 [9600 baud]).....	33
Parameter 27 TX2 Control / Station ID (255 [single station]).....	33
Parameter 28 TX2 Format (2 Condec format).....	34
Printer Parameters.....	35
Parameter 29 Printer Port Select (2 [Serial Port 1]).....	35
Parameter 30 Auto Print LF after CR (1 [yes]).....	35
Parameter 31 End of Print Character (12 [form feed]).....	35
Parameters 32, 33 34, 84, 85, 86, 87, 88, 89 and 90 Print Labels.....	35
Parameters 35, 36, 37, and 38: Print Codes.....	36
Parameter 39 Enable TTL Remote Control (1 [enabled]).....	36
Display Intensity, Battery, Watch Dog Timer.....	36
Parameter 40 Display Intensity (10).....	36
Parameter 41 Battery Backup (0 [no]).....	36
Parameter 42 Enable Watch Dog Timer (0 [no]).....	36
Parameters 43-50 Fixed Registers.....	36
Parameters 51-58 Keyboard Event Functions.....	37

**Parameter Functions ..... 38**

Parameter Functions.....	38
Access Parameter Functions.....	39
Function 59 Display Calibration Audit Number.....	39
Function 60 Calibrate Scale - Deadload First.....	40
Function 61 Calibrate Scale - Span First.....	40
Function 62 Calibrate Deadload Only.....	40
Function 63 Adjust Gain Calibration.....	41
Adjust Gain – 5 Point Linearization.....	41
Function 64 Configure Passwords.....	42
Function 65 Configure Print Formats.....	43
Modify or Design a Print Format.....	43
Function 66 Set Time and Date.....	47
Function 67 Display Operation Parameters.....	47
Function 68 Print Operation Parameters.....	47
Function 69 Diagnostic Tests.....	48
Function 70 Initialize Operation Parameters to Factory Defaults.....	48
Function 71 Configure Event Monitor.....	49
Function 72 Scale Basic Function Editor.....	49
Function 73 Initialize Function Memory.....	49
Function 74 Configure Timers.....	50

Parameter 75 Enable Peak Detect .....	50
Parameter 76 Debug mode for Event monitors and Scale Basic .....	50
Function 78 Initialize ID memory.....	50
Parameter 79 Enable Multi-point Linearization .....	50
Function 80 Calibrate - Multi-point Linearization .....	51
<b>Diagnostic Tests .....</b>	<b>52</b>
Table of Diagnostic Tests.....	52
Diagnostic Test 1: Serial Com Port 1 - Display Input Data .....	53
Diagnostic Test 2: Serial Com Port 1 – Display Errors .....	53
Diagnostic Test 3: Serial Com Port 1 - Transmit Data.....	53
Diagnostic Test 4: Serial Com Port 2 - Display Input Data .....	53
Diagnostic Test 5: Serial Com Port 2 – Display Errors .....	54
Diagnostic Test 6: Serial Com Port 2 - Transmit Data.....	54
Diagnostic Test 7: Test parallel output.....	54
Diagnostic Test 8: Test A/D .....	55
Diagnostic Test 9: Perform internal memory test.....	55
Diagnostic Test 10: Lamp Test .....	55
Diagnostic Test 11: Print the EAROM Configuration Table .....	55
Diagnostic Tests 12 & 13: Loop Back Tests .....	55
<b>Troubleshooting.....</b>	<b>56</b>
Problems And Probable Causes.....	56
Error Messages .....	57
<b>Hardware and Wiring .....</b>	<b>58</b>
Load Cell Connector - TB3 .....	58
Serial Port 1 Connector - TB 1 .....	59
Serial Port 2 Connector - TB 2.....	59
TTL I/O Port Connector - TB 4.....	60
P.C. Board Diagram - Connectors, Jumpers, and Switches.....	61
Sample Cable Drawings.....	62
Load Cell.....	62
IDS150A/152/160/320 .....	62
DT210/IDS550/IDS710/PC (Continuous Output Port).....	63
Hewlett Packard Smart Wand HBCR-8xxx series.....	64
Parallel (Centronix) Printer .....	64
Remote Switch Inputs.....	65
ANALOG OUTPUT OPTION .....	66
<b>440 Specifications.....</b>	<b>68</b>
<b>ASCII CHART.....</b>	<b>70</b>

# Introduction

---

Congratulations on your purchase and welcome to the IDS440 User's Manual. This manual describes the installation, calibration and setup, and operation of the IDS440 weigh scale indicator. The IDS440 is a microprocessor based weight indicator with rugged design and state-of-the-art technology. It is designed for use in industrial environments to perform the following functions:

- Analog to Digital conversion (A/D) - converts the analog signal from a strain gauge "load cell" to a numeric weight.
- Signal Processing - filters electrical and mechanical noise from the load cell signal using electronic circuits and digital filtering.
- Basic Weighing - push button zero, tare functions (push button and keyboard tare), display of gross or net weight and scale status, and transmission of weight data to a printer and a computer.
- Additional Functions - trip level event monitor, programmable "Scale Basic" functions, TTL level 'setpoint' inputs and outputs, and remote control via TTL inputs or RS232 serial input.

The IDS440's stainless-steel enclosure is designed for industrial environments and can be used in wash down applications.

The IDS440 has two bi-directional serial communication ports that are used for printer output, bar code input, computer communications, and remote control. The serial ports support RS232, RS422, RS485, and 20ma Current Loop communication.

The IDS440 has one parallel TTL I/O port for output to a printer or for setpoint input/output. The TTL inputs can be used for remote control (ZERO, TARE, GROSS/NET, PRINT).

Options available include time & date, networking, analog output, solid-state relay board, and peak hold.

## What's In Each Section

---

This manual is organized and divided into separate sections, which describe the installation, calibration, setup, operation, and testing of the IDS440. Some Sections, such as **Installation, Setup** and **Calibration** are intended for trained scale technicians familiar with the installation of computer equipment. Other sections present information applicable to a user, installer, or system integrator.

The importance of certain information in various sections depends on what features of the IDS440 are to be utilized. It is recommended that each installer and user review all sections of the manual and determine what information is useful to his personal needs.

**Installation and Setup** allow a user to quickly get the IDS 440 in a working manner for simple use and testing.

**Set Operation Parameters** and **Parameter Functions** concentrate upon additional versatile scale setup parameters and interfacing to peripheral devices such as printers, computer, PLCs, remote displays/scoreboards, etc.

**Diagnostic Tests** and **Troubleshooting** supply fast and simple diagnostic and troubleshooting instructions for virtually any abnormal situation.

**Hardware and Wiring Diagrams** provides all external-wiring instructions.

### Scale Basic / Event Monitor Programming

The IDS440 Indicator offers "Scale Basic" programming capabilities, which allow you to customize the operation of the IDS440 to your application. Scale Basic is designed to be similar to the common BASIC language used in computer programming.

Event Monitors work with Scale Basic functions to provide event driven programming capabilities, such as activating setpoint relays. Events trigger actions; Event Monitors activate Scale Basic functions.

A Scale Basic & Event Monitor Programming Manual may be obtained through your IDS Dealer

## **WARRANTY INFORMATION**

---

### **LOAD CELL CENTRAL LIMITED WARRANTY.**

Load Cell Central, warrants that the products furnished are free from defects in material and workmanship and perform to applicable, published Load Cell Central, specifications for one (1) year from the date of shipment.

**THIS WARRANTY IS IN LIEU OF ANY OTHER WARRANTY EXPRESSED OR IMPLIED. IN NO EVENT SHALL LOAD CELL CENTRAL. BE LIABLE FOR LOSS OF PROFITS, OR INDIRECT, SPECIAL OR CONSEQUENTIAL DAMAGES, OR FOR OTHER SIMILAR DAMAGES ARISING OUT OF ANY BREACH OF THIS WARRANTY PROVISION.**

The liability of Load Cell Central shall be limited to repairing or replacing, WITHOUT CHARGE, any defective products which are F.O.B Load Cell Central. Plant. Equipment or parts which have been subject to abuse, misuse, accident, alteration, neglect, unauthorized repair or installation are not covered by warranty. Load Cell Central shall have the right of final determination as to the existence and cause of defect. As to items repaired or replaced, the warranty shall continue in effect for the remainder of the warranty period, or for ninety (90) days following date of shipment by Load Cell Central of the repaired or replaced product, whichever period is longer. No liability is assumed for expendable items such as lamps and fuses. No warranty is made with respect to customer equipment or products produced, to Buyer's specifications except as specifically stated in writing by Load Cell Central and contained in the contract. In no case is product to be returned without first obtaining permission and a Customer Return Authorization Number (RMA) from Load Cell Central. Product being returned during or after the original warranty period should be carefully packed and sent prepaid and insured along with an explanation of the problem. Customer shall be responsible for all damages resulting from improper packaging or handling, and for loss in transit. If it is found that Load Cell Central product has been returned without cause and is still serviceable, customer will be notified and Product returned at customer's expense. Repairs or replacements made by Load Cell Central on Products under warranty will be returned, shipped at NO CHARGE by method of shipment Load Cell Central deems most advantageous.

**EXCEPT AS SPECIFICALLY PROVIDED HEREIN, THERE ARE NO OTHER WARRANTIES EXPRESSED OR IMPLIED, INCLUDING BUT NOT LIMITED TO ANY IMPLIED WARRANTIES OF MERCHANTABILITY OR FITNESS FOR A PARTICULAR PURPOSE.**

### **RETURN POLICY**

Any piece of equipment purchased by the original purchaser can only be returned for credit or exchange during the first 45 days after shipment. This policy excludes any returns for warranty consideration. Items returned for other than warranty is subject to a restock fee equal to 25% of the list price of the hardware. This fee is assessed for packaging, handling, testing, inspection, and the resultant paperwork that is required to receive and return the hardware to stock for resale.

All such items should be returned in its original shipping container. Any damage not reported when the purchaser originally received the hardware or software is also subject to reasonable repair fees to bring it back to new condition. The purchaser will be advised of these fees in writing at the time they are assessed.

All items returned should be returned with a Return Material Authorization number ( RMA ) issued by a LCC employee. The RMA number should be clearly marked on the outside of the box.



# General Description

This section gives you a general description on the operation of the IDS440's keyboard and display. The keyboard is used to initiate weighing functions, for data entry, maintenance, setup, and testing. The numeric display is used for weight and error display and for data entry. The LED status lights indicate the status of the weigh scale. Additional information about the keyboard and display is provided in section: **Using the IDS440.**

## IDS440 Display and Keyboard Diagram

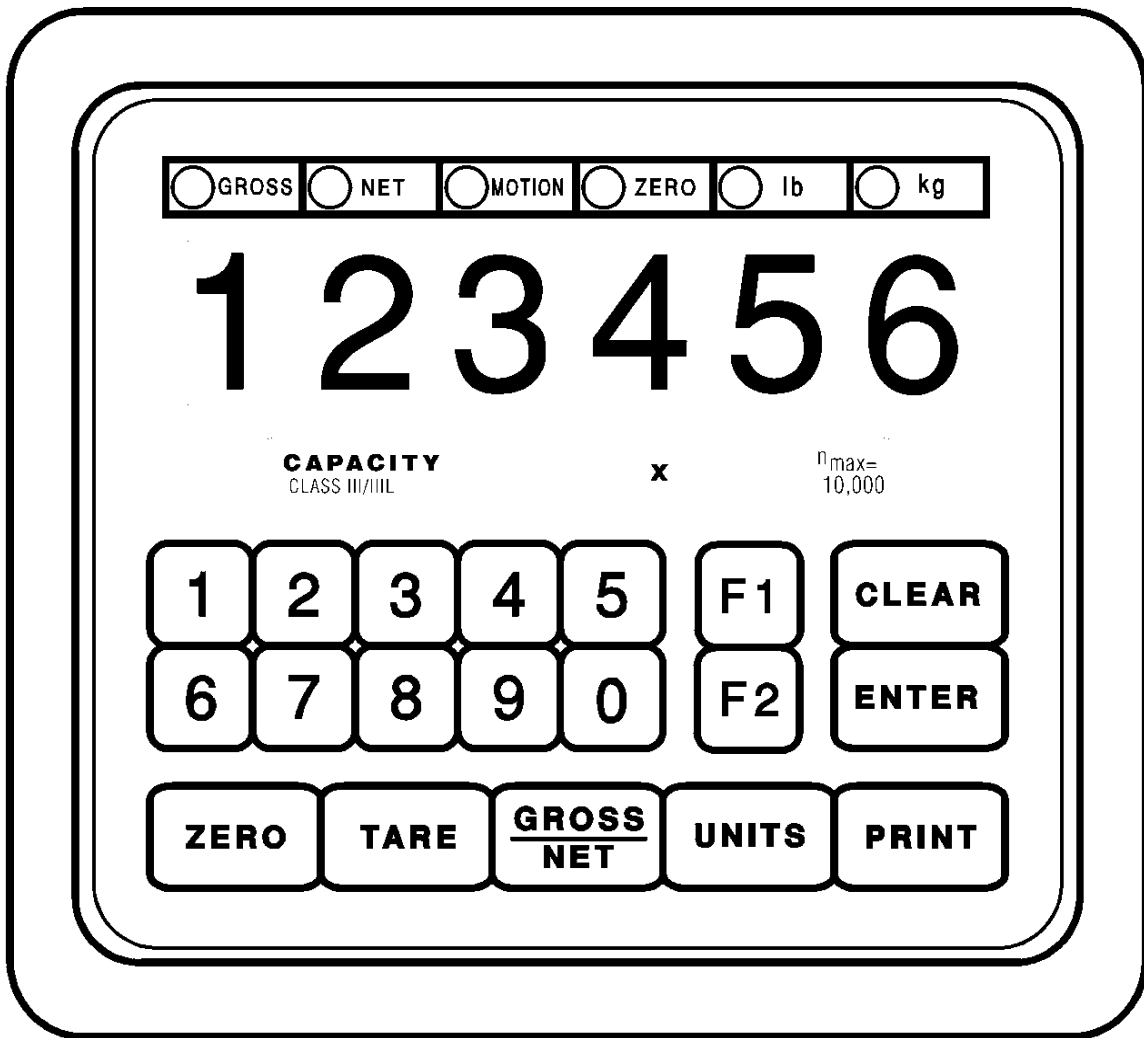

## The IDS440 Display

---

The IDS440 DISPLAY consists of a 6 character NUMERIC display and 6 statuses LED's. The NUMERIC display is normally used to display the weight on the scale. The LED's display the scale status. When lighted they indicate the following conditions:

GROSS-	The number displayed is the gross weight on the scale.
NET -	The number displayed is the net weight on the scale.
MOTION-	The weight on the scale is changing (not stable).
ZERO-	The scale is at "Center of Zero".
lb-	The weight displayed is in increments of pounds.
kg-	The weight displayed is in increments of kilograms.

## The IDS440 Keyboard

---

The keyboard is used to initiate weighing functions and for data input and setup of the IDS440. It is divided into 3 sections: Numeric Keypad, Function Keys, and Control keys as shown on the previous page.

### Numeric Keypad

The numeric keypad is used for numeric data entry. Alphanumeric entry is performed using a three-digit code for every alphanumeric character. Some system parameters may require alphanumeric entry. Instructions for alphanumeric entry are provided where needed.

### Function Keys

The function keys ZERO, TARE, GROSS/NET, UNITS and PRINT are used to perform the functions of zeroing the scale, tarring the scale, switching the weight display between gross and net display, switching the weight display between LB and KG display, and printing the weight. The function keys F1 and F2 are programmable using Scale Basic functions.

### Control Keys

The control keys ENTER, and CLEAR are used to control the data entry operations for ID's, setpoints and setup.

# Installation and Setup

---

This section provides information about unpacking, installing, and setup of the IDS440. It also directs the installer to the appropriate sections of the manual for hardware and setup installation.

## Unpacking the IDS440

---

Installation begins with unpacking the IDS440. Observe any instructions or cautions, which appear in the shipping container. Check the items in the shipping container against the following item check list or the packing list. IDS, Inc. will not accept responsibility for shortages against the packing list unless notified within 30 days. All equipment and accessories are inspected and tested by IDS before shipment. Inspect the equipment carefully. If shipping damage is evident, notify the carrier immediately. Take photographs if necessary. You are responsible for final claim and negotiations with the carrier. Save the packing and shipping container in case you need to store, return, or transport the IDS440 for any reason.

### Item check list

- IDS440 - Weight Scale Indicator
- Power cord
- This User's Manual
- Capacity labels
- A sheet that describes the capacity label placement

NOTE: The container may include additional items that have been purchased separately.

## Installation Guide

---

### Connect IDS440 to load cell

Connect the load cell to the Load Cell Terminal Block located inside IDS440's enclosure. See the **HARDWARE INSTALLATION AND WIRING** section for pin assignments and a sample cable drawing.

### Connect IDS440 to the printer (optional)

The IDS440 can be connected to a printer using Com Port 1 (TB1) for RS232 or Current Loop interfaces or by using the TTL I/O Port (TB4) for Centronix compatible interfaces. See **Hardware and Wiring Diagrams** for pin assignments and sample cable drawings. See **Set Operation Parameters**, and **Parameter Functions** for other communication setup parameters.

Connect IDS440 to host device (optional)

The Serial Communications Port 2 (TB2) provides a continuous output of scale data. This is used for connection to a host device such as a computer or to a remote display (scoreboard). Continuous output transmission can be enabled or disabled and the output format can be customized to interface with the host device. See **Hardware and Wiring Diagrams** for pin assignments and sample cable drawings. See **Set Operation Parameters**, and **Parameter Functions** for other communication setup parameters.

### Apply AC Power to the IDS440

After the load cell and optional equipment has been connected, apply power through the power cord.

Note: The socket outlet should be installed near the equipment and shall be easily accessible.

On power-up, the IDS440 performs the following tests:

1. A/D Conversion Test - the IDS440 verifies that A/D conversions are taking place.
2. Keyboard Scan - the keyboard is scanned to verify that no keys are engaged.
3. Memory Test - the IDS440 displays "rTEST" while it performs a memory test on internal memory. If a problem is encountered during the test, an error message is displayed.
4. Lamp Test - all segments on the numeric display and all LED's are turned on for 5 seconds.
5. Conversion Display - the IDS440 displays "Ad xxx", where "xxx" is the conversion count. This test takes approximately 10 seconds.

6. Stability Check - the IDS440 displays "C xxxx" where "xxxx" is the raw data difference in scale readings. The IDS440 waits until the data difference is within a stable range.

To exit the above power on test functions, press the CLEAR key during any test. This is possible only if the IDS440 has not been locked.

The IDS440 is now ready for **initialization**, calibration, and configuration. Continue with Setup Guide.

## Setup Guide

---

Setup the IDS440 in the following order:

### Initialize to Factory Defaults

The IDS440 is initialized at the factory. It must be re-initialized if the program memory (EPROM) or the parameter memory (EAROM) is replaced. The Initialize function clears the memory and sets the configuration parameters to their default values. Use parameter function 70 described in **Parameter Functions** to initialize the IDS440.

**NOTE: Calibration and setup must be performed after the IDS440 is initialized.**

### Setup & "Quick" Calibration Guide

The IDS440 should be configured BEFORE calibration. **Set Operation Parameters** details all of the scale parameters that are available. To quickly get the IDS440 up and running, the following Quick Calibration Guide lists only the mandatory parameters that must be defined. Enter the following scale parameters using the selection outlined in **Set Operation Parameters** and **Parameter Functions**.

Parameter (section)	Purpose (Factory Setting)
1 (Set Operation Parameters)	Load Cell mv/V (3)
11 (Set Operation Parameters)	Decimal Point (none)
12 (Set Operation Parameters)	Count-by (1)
17 (Set Operation Parameters)	Full Scale Graduations (10,000)
18 (Set Operation Parameters)	Overload Graduations (10,200)
60 (Parameter Functions)	Calibrate Scale

### Calibrate the Weight Indicator

Use Parameter Function 60 to calibrate the weight indicator (page 6-3).

# Using the IDS440

---

The IDS440 has 7 function keys located at the bottom of the keyboard, a numeric keypad, and 2 control keys (ENTER, and CLEAR). This section of the IDS440 manual describes what the keys are used for and how to use them.

## Keyboard Layout

---

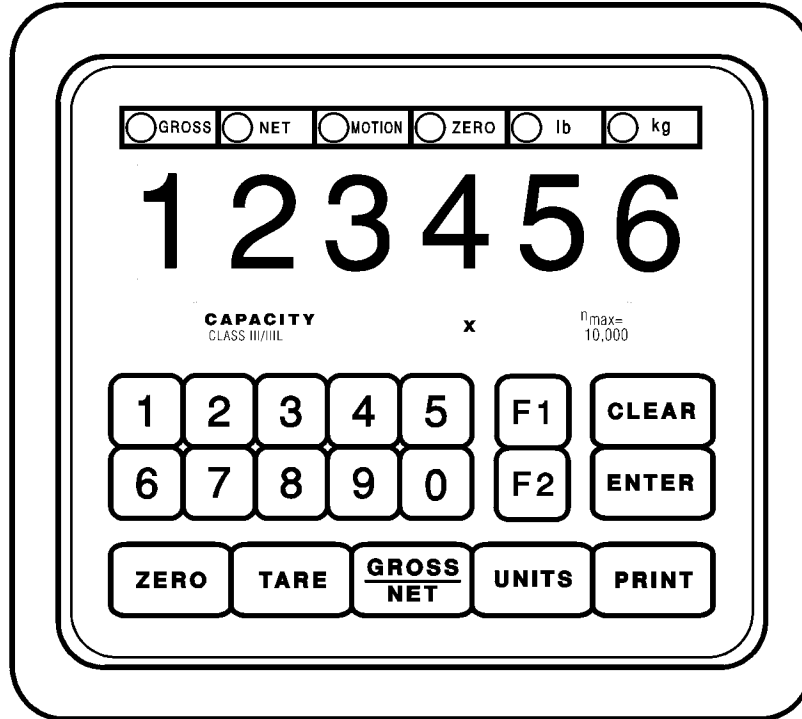

## Operation of Function Keys

---

The function keys are located on the bottom of the IDS440's front panel.

### Zero

Press the ZERO key to zero the scale. The following conditions must be met for the ZERO key to function:

- The gross weight is within the configured zero acquisition range: 1% to 100% of full scale.
- The scale is stable (no motion).

## Tare

### **AUTO TARE:**

Press the TARE key. The IDS440 reads the weight on the scale and stores it in the tare register. The IDS440 switches to NET mode and displays the net weight.

### **KEYBOARD TARE:**

Use the numeric keys to enter a tare weight. Press the TARE key. The IDS440 stores the entered weight in the tare register and switches to NET display mode.

### **CLEAR TARE:**

Press the numeric ZERO key. Press the TARE key. The tare weight is cleared to zero and the IDS440 switches to the GROSS mode.

## Gross/Net

Press the Gross/Net key to alternate between Gross and Net display modes.

## Print

Press the PRINT key to print weight data. Page format 1 is printed if the IDS440 is in Gross display mode; page format 2 is printed in the Net display mode. See section **Parameter Functions** for setup of print formats.

## F1 and F2

The F1 and F2 keys can be configured to execute any scale basic function (parameters 57 and 58).

When the indicator is in data entry mode, the F1 key can be used for entering a minus sign; the F2 key can be used to enter a decimal point.

## Memory Register Entry

Use the numeric keypad to enter the memory register number (1 to 16). Press the ENTER key. The IDS440 displays "reg xx" for 1 second and then displays the current memory register value. Press the CLEAR key if no change is to be made, or enter a new value and then press the ENTER key. Memory registers are used by the Event Monitor to calculate setpoint values. NOTE: memory registers are set to zero at power up unless the battery back up is enabled CFG 41.

## Execute a Scale Basic Function

The IDS440 provides up to 16 user programmable functions. User programs 1 thru 16 can be executed by entering 1 to 16 respectively. See the "Scale Basic / Event Monitor" manual for more information.

## Display Time/Date

Enter 19 to display the time, press Enter to display the date, press Enter again to return to Gross/Net display.





# Built In Application Programs

---

The following built in programs are available:

1. Fill to Setpoint.
2. Checkweigh: Under/Between/Over.
3. Weigh-in / Weigh-out.
4. Axle Weigh – Short Scale.
5. Axle Weigh – Long Scale.
6. ID Tare and Total.
7. Peak Hold.

Use parameter function 73, “Initialize Function Memory”, to activate a built in program. The initialize function erases function memory and setpoint monitor memory, and initializes all parameters that have a password level of 1 or 2. Use parameter function 73 before configuring parameters with password level of 1 or 2.

## #1 Fill to Setpoint

---

Press F1 key to enter a setpoint. Place an empty container on the scale. Press F2 key to begin filling. TTL output 1 turns on until the weight on the scale is equal or greater than the setpoint.

### Installation

---

Connect TTL output 1 to relay or lamp actuator.

TB4 - Pin 1   TTL output 1

TB4 - Pin 16   Ground (GND)

### Setup Parameters:

---

(See chapter 5: Set Operation Parameters for setup details)

Parameter 43 Minimum scale weight to begin filling. Verifies that a container is on the scale. Set to 0 if there is no minimum.

Parameter 44 Minimum fill amount. Set to some small value to insure that a fill amount has been entered.

Parameter 45 Maximum fill amount. Maximum fill weight that will ever be used.

Parameter 46 Scale empty weight. Maximum weight to begin fill. Verifies that an empty container is on the scale.

## Operators Functions

---

### Enter setpoint

Press **F1** key to enter the setpoint. Enter the setpoint weight, then press the ENTER key.

### Start fill operation

Place the container on the scale (if required). Press **F2** key to begin fill operation.

### Stop fill operations

Press the **Clear** key to stop fill operation.

### Print Results

Press the Print key to print the Gross, Tare, and Net results of the fill operation.

### Error Codes

Error 30 = scale not empty

Error 31 = minimum weight error: container is not on scale

Error 32 = tare weight error: tare function failed, scale not stable (motion)

Error 33 = setpoint less than minimum setpoint amount

Error 34 = setpoint more than maximum setpoint amount

## # 2 Checkweigh: Under/Between/Over

---

The indicator monitors the scale for activity. When the scale goes above the 'empty' weight, the indicator waits for stable weight, and then outputs an indication of Under, Between (OK), or over. The cycle resets when the scale goes below the empty weight.

### Installation

---

Connect TTL outputs to relay or lamp actuators.

Under weight indication	TTL 1	TB4 - Pin 1
Between weight indication	TTL 2	TB4 - Pin 2
Over weight indication	TTL 3	TB4 - Pin 3
Ground	GND	TB4 - Pin 16

Configure 'empty' scale weight. (Parameter 43)

## Operators Functions

---

### Enter setpoint weights

Press the F1 key. The display prompts "SP 1. Use the numeric keyboard to enter setpoint 1, then press the ENTER key. The display prompts "SP 2". Use the numeric keyboard to enter setpoint 2, then press the ENTER key. NOTE: use the F2 key to enter a decimal point if needed.

### Recalculate

Press the F2 key to re-check the weight on the scale.

## # 3 Weigh-in / Weigh-out

---

This program uses the ID memory for weigh-in / weigh-out transactions. An ID record is created using the Weigh-in function. The Weigh-out function recalls the ID, calculates Gross/Tare/Net of the transaction, prints the transaction, and adds the net weight to the ID's totals register. The ID data is saved for further weigh-in/weigh-out transactions, or weigh-out only transactions. A sequential transaction number is maintained for printing purposes.

### Weigh-In

Press the **F1** key. The display prompts "id". Enter up to 8 digits for the weigh-in ID and then press the ENTER key. The scale weight is stored in the ID's tare register and print page 3 is sent to the printer. For keyboard tare, enter the ID number and press the TARE key (not the ENTER key). Enter the tare weight and press the ENTER key. If the ID has been weighed in but not weighed-out then "Err 20" is displayed. Press the CLEAR key to exit without changing the ID data, press the ENTER key to enter the new ID data.

### Weigh-Out

Press the **F2** key. The display prompts "id". Enter up to 8 digits for the weigh-out ID and then press the ENTER key. The indicator recalls the ID from memory, calculates the gross, tare and net weights, totals the net weight and sends the weigh-out data (page 2) to the printer. If an ID is entered that is not found in memory the displays "Err 21". Press the CLEAR key to exit the weigh-out function.

The print formats label "(IN) GROSS" for weigh-in gross transactions, "(IN) TARE" for weigh-in tare transactions, and "MEM TARE" to designate Memory tare for ID's recalled 2 or more times.

### Print ID's, Display ID's, Clear Totals, Erase ID's

Entering ID 0 accesses the ID maintenance functions. Press the F1 (or F2) key, press the numeric 0 key, and then press the ENTER key. The display prompts "rePort". Press the UNITS (↓) key or the PRINT (↑) key to scroll through the ID file maintenance menu.

**REPORT:** Press the ENTER key when the display prompts "rePort". The display then prompts "id". Enter an ID number to be printed or enter the numeric 0 to print all ID's.

**DISPLAY ID's:** Press the ENTER key when the display prompts "diSPLA". The display then prompts "id". Enter an ID number to display the data in its registers, or enter 0 to scan ID memory.

**CLEAR TOTALS:** Press the ENTER key when "CLEAR" is displayed. The display prompts "id". Enter an ID number to clear or enter the numeric 0 to clear all ID totals.

**ERASE ID'S:** Press the ENTER key when the display prompts "ErASE". The display then prompts "id". Enter an ID to be erased or enter the numeric 0 to erase all ID's.

**REBUILD ID MEMORY:** Press the ENTER key when the display prompts, “rebuiLd”. The display then prompts “id”. Enter the numeric 0 then press ENTER to rebuild ID memory.

**COUNT UNUSED ID’S:** Press the ENTER key when the display prompts “Count”. The display prompts “FrExxx” where xxx is the number of unused ID records in memory.

### Set Beginning Sequence Number

Use the numeric keypad to enter number 9. The display prompts "reg 9" for 1 second and then displays the current value. Press the CLEAR key if no change is to be made, or enter a new value and then press the ENTER key. The next sequence number printed will be the entered value +1.

### Options

- **Print key:** Set parameter 52 = 4 (execute user function 4) to enable the print key to print the weight on the scale. The print data is sent to Serial Communications Port 1. If units other than lb are used, change print label 85 to the correct units. (This option is not available for printers that use the parallel output port).
- **Unit’s key:** Set parameter 53 = 127 (execute Units function) if weighing is dual units is required.

### Notes

- The ID file maintenance functions are password level 1 protected. If a password has been configured (function 64) the operator will be prompted for the password before the file maintenance menu is displayed.
- ID memory is cleared to zero at power up unless CFG parameter 41 (battery back up enable) is set to 1.

## # 4 Axle Weigh – Short Scale

---

Automatically weigh multiple axles (or containers), print each axle weight, and print axle total.

### Installation

---

Connect the Red light / Green light relays.

Green light = TTL out 1      TB4 pin 1

Red light =    TTL out 2      TB4 pin 2

### Setup Parameters

---

Configure the following parameters:

Parameter 43	Trip level weight. Determines when an axle is on the scale.
Parameter 74, 1	Red light turn delay timer. This provides a delay time before the Red light output is turned on.
Parameter 74, 2	Green light turn delay timer. The amount of delay time before the Green light is turned on.
Parameter 74, 3	Finish timer. Amount of time to wait before automatically activating the finish function.

### Operators Functions

---

The unit is capable of operating unattended, with no operator intervention. The indicator determines when an axle is on the scale by the increase (or decrease) of weight on the scale.

A finish timer (parameter 74-3) determines when to complete a weigh cycle (print total and wait for empty scale).

Press the **F1** key to manually finish a weigh cycle before finish timer has timed out.

Press the **F2** key to abort weigh cycle.

## # 5 Axle Weigh – Long Scale, Unattended

---

Automatically weigh multiple axles (or containers), print each axle weight, and print axle total.

### Installation

---

Connect the Red light / Green light relays.

Green light = TTL out 1      TB4 pin 1

Red light =    TTL out 2      TB4 pin 2

### Setup Parameters

---

Configure the following parameters:

- |                 |  |
|-----------------|--|
| Parameter 43    | Trip level weight. Determines when an axle is on the scale.                                      |
| Parameter 74, 1 | Red light turn delay timer. This provides a delay time before the Red light output is turned on. |
| Parameter 74, 2 | Green light turn delay timer. The amount of delay time before the Green light is turned on.      |
| Parameter 74, 3 | Finish timers. Amount of time to wait before automatically activating the finish function.       |

### Operators Functions

---

The unit is capable of operating unattended, with no operator intervention. The indicator determines when an axle is on the scale by the increase of weight on the scale.

A finish timer (parameter 74-3) determines when to complete a weigh cycle (print total and wait for empty scale).

Press the **F1** key to manually finish a weigh cycle before finish timer has timed out.

Press the **F2** key to abort weigh cycle.



## # 6 ID, Tare, and Total

---

This program uses the ID memory to store tare weights and totals.

### Enter ID Tare Data

Press the **F1** key. The display prompts "id". Enter up to 8 digits for ID and then press the ENTER key. The display prompts "tArE". Enter the tare weight.

### Recall ID and Tare

Press the **F2** key. The display prompts "id". Enter up to 8 digits for the weigh-out ID and then press the ENTER key. The indicator recalls the ID from memory and copies the ID tare to the tare register.

### Print and Total ID

Recall an ID and then press the Print key. The ID number, Gross, Tare, and Net are printed. The Net weight is added to the ID's totals register.

### Print ID's, Display ID's, Clear Totals, Erase ID's

Entering ID 0 accesses the ID maintenance functions. Press the F1 (or F2) key, press the numeric 0 key, and then press the ENTER key. The display prompts "rePort". Press the UNITS (↓) key or the PRINT (↑) key to scroll through the ID file maintenance menu.

**REPORT:** Press the ENTER key when the display prompts "rePort". The display then prompts "id". Enter an ID number to be printed or enter the numeric 0 to print all ID's.

**DISPLAY ID's:** Press the ENTER key when the display prompts "diSPLA". The display then prompts "id". Enter an ID number to display the data in its registers, or enter 0 to scan ID memory.

**CLEAR TOTALS:** Press the ENTER key when "CLEAr" is displayed. The display prompts "id". Enter an ID number to clear or enter the numeric 0 to clear all ID totals.

**ERASE ID'S:** Press the ENTER key when the display prompts "ErASE". The display then prompts "id". Enter an ID to be erased or enter the numeric 0 to erase all ID's.

**REBUILD ID MEMORY:** Press the ENTER key when the display prompts, "rebuiLd". The display then prompts "id". Enter the numeric 0 then press ENTER to rebuild ID memory.

**COUNT UNUSED ID'S:** Press the ENTER key when the display prompts "Count". The display prompts "FrExxx" where xxx is the number of unused ID records in memory.

## Set Beginning Sequence Number

Use the numeric keypad to enter number 1. The display prompts "reg 1" for 1 second and then displays the current value. Press the CLEAR key if no change is to be made, or enter a new value and then press the ENTER key. The next sequence number printed will be the entered value +1.

## Notes

- The ID file maintenance functions are password level 1 protected. If a password has been configured (function 64) the operator will be prompted for the password before the file maintenance menu is displayed.
- ID memory is cleared to zero at power up unless parameter 41 (battery back up enable) is set to 1.

## # 7 Peak Hold Function

---

The peak hold register maintains the peak weight detected by the weight indicator.

### Enable Peak Hold

Access configuration parameter 75. Enter a 1 to enable peak hold, enter a 0 to disable peak hold.

### Clear Peak Hold Register

Press the CLEAR key to reset the peak hold register to 0.

Use the Scale Basic built in function Clear Peak [143] to reset the peak hold register.

### Display Peak Weight

Use the GROSS/NET key to scroll thru the display options as follows:

Initial mode:	Display gross weight.	Gross LED on.
First GROSS/NET press:	Display net weight.	Net LED on.
Next GROSS/NET press:	Display gross peak weight.	Gross LED flashing.
Next GROSS/NET press:	Display net peak weight.	Net LED flashing.
Next GROSS/NET press:	Display gross weight.	Gross LED on.
Etc.		

### Print Peak Weight

Use function 65 (Configure Print Formats) to format the print output using:

Print Item 19:	print Gross Peak weight.
Print Item 20:	print Net Peak weight.



# Set Operation Parameters

---

This section describes the operation parameters of the IDS440 and how their settings affect the operation of the weight indicator.

## Access Operation Parameters and Parameter Functions

---

The parameters are accessed by holding the CLEAR key down and then pressing the ENTER key. The numeric display will prompt “CFG xx” where xx is the currently selected parameter. Enter the parameter number to be modified and then press the ENTER key. NOTE: the UNITS key (↓) and the PRINT key (↑) can be used to scroll the CFG parameter number. Press the UNITS key to increment the CFG number, press the PRINT key to decrement the CFG number.

To exit configuration and store changes, press the CLEAR key when “CFG xx” is being displayed.

To exit configuration and NOT store changes, enter 999 when “CFG xx” is being displayed. The display prompts “Abort”. Press the ENTER key to abort (exit without saving changes) or press the CLEAR key if you do not want to abort.

## Operation Parameters Reference Tables

---

The reference tables provide an overview of the operation parameters. The sections following the reference tables describe the setup parameters in detail and the procedures for modifying them. Use the ‘Field Settings’ column of the reference tables to document any changes to the setup parameters.

Reference Table column headings descriptions:

- **No.:** Use this number to access the parameter to be modified. For example to modify the Digital Filter enter CFG 2.
- **Parameter Name:** The name of the parameter.
- **Default:** The value set at the factory. The Parameter Function “Initialize Operation Parameters to Factory Defaults” sets the parameter to this value.
- **Max Value:** The maximum value for numeric parameters, the maximum number of characters for alphanumeric parameters.
- **Pass:** The IDS440 has 4 password levels. Level 1 requires entering password-1 before accessing the parameter. Level 2 requires password-2. Level 3 requires password-2 and the Lock Switch to be in the unlocked position. Level 4 inhibits Scale Basic functions from being uploaded to a PC.
- **Field Setting:** Record any changes to the parameters in the Field Setting column.

**Scale Parameters**

No	Parameter Name	Default	Max Value	Pas	Field Setting
1	Loadcell mv/v	3	4	3	
2	Digital filter	9	18	3	
3	Display Update Rate	1	200	3	
4	Motion delay time	6	250	3	
5	Motion band	6	250	3	
6	Motion blanks display	0 (no)	1	3	
7	Zero tracking delay	0	250	3	
8	Zero tracking band	12	250	3	
9	Push button zero percent	100	100	3	
10	Primary units type	1 (lb)	6(oz)	3	
11	Decimal point position	0	4	3	
12	Count-by	1	100	3	
13	Alternate units type	2 (kg)	6(oz)	3	
14	Alt decimal point	1	4	3	
15	Alternate count-by	5	100	3	
16	Alt conversion factor	45,360		3	
17	Full Scale display digits	10,000	120,000	3	
18	Over Weight dd	10,200	120,200	3	
19	Deadload offset			3	
20	Disable Power-On Zero	1	1	3	
21	Deadload Factor			3	
22	Weight conversion fact.			3	

**I/O Port Parameters**

No	Parameter Name	Default	Max Value	Pas	Field Setting
23	Serial port 1 mode	4(8N1)	6	2	
24	Serial port 1 baud rate	1(9600)	6	2	
25	Serial port 2 mode	4(8N1)	6	2	
26	Serial port 2 baud rate	1(9600)	6	2	
27	TX2 control / Station Id	255	255	1	
28	TX2 Data Format	1 (AND)	4	2	
29	Printer port select	2 (Com1)	2	2	
30	Autoprint LF after CR	1 (yes)	1	2	
31	End Of Print character	12 (ff)	255	2	
32	Print label 32		16 char	2	
33	Print label 33		16 char	2	
34	Print label 34		16 char	2	
84	Print label 84		30 char	2	
85	Print label 85		30 char	2	
86	Print label 86		30 char	2	

87	Print label 87		30 char	2	
88	Print label 88		30 char	2	
89	Print label 89		30 char	2	
90	Print label 90		30 char	2	
35	Print code 1		3 codes	2	
36	Print code 2		3 codes	2	
37	Print code 3		3 codes	2	
38	Print code 4		3 codes	2	
39	TTL remote control	1 (yes)	1	2	

### Display Intensity, Battery, Watchdog Timer

No	Parameter Name	Default	Max Value	Pas	Field Setting
40	Display intensity	10	15	2	
41	Battery backup enable	0 (no)	1	2	
42	Enable watch dog timer	1 (yes)	1	1	

### Fixed Setpoints

No	Parameter Name	Default	Max Value	Pas	Field Setting
43	Fixed setpoint 43	0		1	
44	Fixed setpoint 44	0		1	
45	Fixed setpoint 45	0		1	
46	Fixed setpoint 46	0		1	
47	Fixed setpoint 47	0		1	
48	Fixed setpoint 48	0		1	
49	Fixed setpoint 49	0		1	
50	Fixed setpoint 50	0		1	

### Keyboard Events

No	Parameter Name	Default	Max Value	Pas	Field Setting
51	Power on start	0	255	2	
52	PRINT key	136	255	2	
53	UNITS key	127	255	2	
54	Gross/Net key	128	255	2	
55	TARE key	129	255	2	
56	ZERO key	130	255	2	
57	F1 key	138	255	2	
58	F2 key	139	255	2	

**Parameter Functions**

<b>Fn. No</b>	<b>Function Name</b>	<b>Password Level</b>
59	Display Calibration Audit Number	0
60	Calibrate Scale - Deadload first	3
61	Calibrate Scale - span first	3
62	Calibrate Deadload Only	3
63	Adjust Gain Calibration	3
64	Configure Passwords	2
65	Configure Print Formats	2
66	Set Time and Date	2
67	Display Operation Parameters	0
68	Print Operation Parameters	0
69	Diagnostic Tests	0
70	Initialize Operation Parameters to factory defaults.	3
71	Configure Event Monitor	2
72	Function Editor	2&3
73	Initialize Function Memory	2
74	Set Debug mode for Event monitors and Scale basic fns.	2
75	Enable Peak Detect (optional)	2
76	Set debug mode for event monitors and scale basic fns.	2
78	Erase Id Memory	1
79	Enable Multi-point Linearization (default = disabled[0])	3
80	Calibrate using Multi-point Linearization	3
81	Analog output offset (default = 0)	1
82	Analog output span (default = 10,000)	1
83	Analog output register (default = 0 [disabled])	1

## Scale Parameters

---

The scale parameters configure IDS440 for the weigh platform or load cell that it is connected to. The preceding table titled “SCALE PARAMETERS” lists the scale parameters and their factory settings. Use the “Field Setting” column to record any changes made to the factory default values.

Many of the following parameters are entered in terms of “graduations”. The full-scale graduations can be found by dividing the full-scale weight by the count-by weight. For example, if the scale is configured for 500.00kg x 0.05kg, the full-scale graduations is  $500.00/0.05 = 10,000$  graduations to full scale.

The numbers in parenthesis are the default factory settings.

### Parameter 1. Load Cell mv/V (3 mv/v)

The IDS440 can be used with load cell outputs of 1 mv/V, 2 mv/V, or 3 mv/V. Enter a 1, 2, or 3 for the load cell type used in your application.

Setting	A/D gain
0	200
1 mV/v	100
2 mV/v	100
3 mV/v	50
4	25

### Parameter 2. Digital Filter (9)

The digital filter removes scale vibrations and other noise signals from the weight display. The filter range is between 0 and 18. A setting of 0 provides no filtering; a setting of 18 provides maximum filtering. The higher the filter number, the longer the settle time of the weight display. For example:

Filter Setting	Settle Time
3	0.4 sec
6	0.8 sec
9	1.75 sec
12	3.5 sec
15	7.0 sec

Use the smallest filter setting that provides satisfactory display stability.

### Parameter 3. Display Update Rate (1)

Enter the time between display updates (in tenths of a second). An update rate of 1 causes a 0.1 second delay between display updates, a rate of 200 causes a 20 second delay between updates. NOTE: motion detection is calculated using the weight values of the display rate. If the update rate is 50, the motion calculation is based on weight readings sampled at 0.5sec intervals.



### Parameter 4. Motion Detection Delay (6)

Motion detection delay is used by the motion detection function to determine if the scale is in motion (not stable). Enter the amount of time (in tenths of a second) that the scale must be stable for motion status to be false (scale status = stable).

Example:     0 = disables motion detection.  
               2 = 0.2 second delay before motion = false (stable = true).  
               15 = 1.5 second delay.  
               30 = 3.0 second delay.

### Parameter 5. Motion Detection Band (6)

The motion band is used by the MOTION DETECT function to determine if the scale is in motion (not stable). If the amount of change between display updates (parameter 2) is greater than the motion band, a MOTION status is generated (unstable condition). The motion band is entered in units of  $\frac{1}{4}$  dd, i.e.. For a motion band of:

$\frac{1}{2}$ display division enter 2	$\frac{1}{2} \times 4 = 2.$
2 display divisions enter 8	$2 \times 4 = 8.$
4.5 display divisions enter 18	$4.5 \times 4 = 18.$

### Parameter 6. Display Blanking During Motion (No Blanking)

When display blanking is enabled, the display is blanked (turned off) when the scale is in motion (not stable). Enter a 1 (yes) to enable display blanking, enter a 0 (no) to disable display blanking.

### Parameter 7. Zero Tracking Delay (0)

The automatic zero tracking function removes small deviations from zero. The IDS440 adjusts the zero setting by approximately  $\frac{1}{30}$ <sup>th</sup> of a display digit per delay interval. The delay interval is the number effective A/D conversions between adjustments.

### Parameter 8. Zero tracking band (12)

The zero tracking band is the maximum displacement from zero wherein zero tracking is active. In order for zero tracking to be active, the following conditions must be met:

- Scale weight is within Zero Track Band.
- Scale is stable (no motion)
- Zero Track Band is greater than 0 (zero).

The zero tracking bands are entered in units of  $\frac{1}{4}$  dd, i.e.. For a band of:

$\frac{1}{2}$ display division enter 2	$\frac{1}{2} \times 4 = 2.$
2 display divisions enter 8	$2 \times 4 = 8.$
4.5 display divisions enter 18	$4.5 \times 4 = 18$

**Parameter 9. Push Button Zero Percent (100)**

Enter the percent of full-scale capacity that can be acquired as the zero point with the ZERO key. 1 = 1%, 2 = 2%, ... 100 = 100%.

**Parameter 10. Primary Units Type (1 [lb])**

The scale is calibrated in the primary units. The UNITS key is used to toggle the weight display between primary units and alternate units. Enter the number that corresponds with the primary units:

- 0 = UNDEFINED, no units printed
- 1 = lb
- 2 = kg
- 3 = ton
- 4 = ten
- 5 = gram
- 6 = oz
- 7 = use print label 32 for units
- 8 = use print code 1 for units

NOTE: when parameter 10 is changed, parameters 13 and 16 must be programmed.

**Parameter 11. Decimal Point Position (0 [no decimal point])**

Enter the decimal point position for the primary units display. For example, if the scale is calibrated x 0.05 the decimal position = 2.

**Parameter 12. Count-by (1)**

Enter the primary units count-by. For example, if the scale is configured for:

- |        |               |
|--------|---------------|
| x 0.05 | count-by = 5  |
| x 0.2  | count-by = 2  |
| x 1    | count-by = 1  |
| x 5    | count-by = 5  |
| x 50   | count-by = 50 |

Note: the entry for 0.05 and 5 is the same. The decimal point position (parameter 11) differentiates between the count-by 0.05 and count-by 5.

**Parameter 13. Alternate Units Type (2 [kg])**

Alternate units are the alternate display and print unit of measure that can be used in addition to the primary units. The UNITS switch on the IDS440's keyboard toggles the weight display between primary units and secondary units.

0 = UNDEFINED, no units printed

1 = lb

2 = kg

3 = ton

4 = tne

5 = gram

6 = oz

7 = use print label 32 for units

8 = use print code 1 for units

**Parameter 14. Alternate Decimal Point (1)**

Enter the decimal point position for the alternate units display.

**Parameter 15. Alternate Count-by (5)**

Enter the alternate units count-by.

**Parameter 16. Alt Units Conversion Factor (45,360)**

The IDS440 calculates the alternate weight by multiplying the primary weight by the conversion factor and then dividing by 100,000. The following table lists some common conversions.

**Alternate Units Conversion Factor Table**

<b>Conversion</b>	<b>Conversion Factor</b>	<b>Conv. Fact. x 100,000</b>
lb to kg	0.45359 kg/lb	45,359
kg to lb	2.20462 lb/kg	220,462
lb to ton	0.0005 Ton/lb	50
kg to tonne	0.001 tonne/kg	100
gram to oz	0.352739 oz/gram	352,739
oz to gram	28.3495 gram/oz	2,834,950
lb to lb kg to kg Etc.	1	100,000

Enter the conversion factor x 100,000 for the configured alternate units.

**Parameter 17. Full Scale Graduations (10,000)**

Enter the number of graduations at full scale. The full-scale graduations are calculated using the count-by, decimal position, and full-scale weight.

$$\text{Full Scale Graduations} = \text{Full Scale Weight} / \text{count-by.}$$

For example, if Full Scale Weight = 600.0 and count-by = 0.2 then Full Scale Graduations =  $600.0 / 0.2 = 3000$ .

**Parameter 18. Overload Graduations (10,200)**

Enter the number of graduations at which the scale is in overload status. The IDS440 displays Err oL on the numeric display when the scale weight exceeds overload. For example, if the Full Scale Graduations is 10,000 grads and the scale is rated for 2% overload, then Overload Graduations =  $10,000 + (10,000 \times 0.02) = 10,200$ .

**Parameter 19. Deadload Offset**

This parameter is automatically calculated by the configure function (60 & 80).

**Parameter 20. Disable Power-On Zero (1 [disabled])**

Enter a 1 to disable the power-on zero function. Enter a 0 to enable power-on zero. The power-on zero function attempts to acquire zero when the power on tests have completed. If the weight on the scale is above the zero range the display prompts "Err 0". Press the ENTER key to view the scale weight. Remove the weight from the scale to enter weighing mode.

**Parameter 21. Deadload Factor**

The deadload factor is automatically calculated by the calibration function. This parameter is not accessible from the keyboard.

**Parameter 22. Weight Conversion Factor**

The weight conversion factor is automatically calculated by the calibration function. This parameter is not accessible from the keyboard.

## Serial I/O Ports

---

The IDS440 is equipped with two bi-directional serial communication ports that can communicate to an optional printer, a computer, bar code reader, a score board or other serial communication devices. The baud rate and format can be set independently for each port. Serial port 1 is normally used to output weight data and ID reports to a printer. Serial port 2 is normally used for continuous output of weight data. Continuous transmission can be enabled or disabled and the output format can be customized using Parameters 27 and 28.

Communication between serial devices requires that both devices have the same baud rate (transmission speed), data bit length, and parity. The mode parameter selects the data bit length and parity the baud parameter selects the baud rate.

### Parameter 23 Serial Port 1 Mode (4 [8 data bits, no parity])

Enter the mode number from the table below to select the mode parameter in the mode description column.

Mode Number	Mode Description
1	7 data bits, no parity
2	7 data bits, even parity
3	7 data bits, odd parity
4	8 data bits, no parity
5	8 data bits, even parity
6	8 data bits, odd parity

### Parameter 24 Serial Port 1 Baud Rate (1 [9600 baud])

Enter a baud number from the table below to select a baud rate from the description column. (\*HS baud rates for the 100 samples per sec version only).

Baud Number	Baud Description
1	9600 Baud
2	4800 Baud
3	2400 Baud
4	1200 Baud
5	600 Baud
6	300 Baud (* HS 19.2K)
7	150 Baud (*HS 38.4K)

**Parameter 25 Serial Port 2 Mode (4 [8 data bits, no parity])**

Enter the mode number from the table below to select the mode parameter in the mode description column.

Mode Number	Mode Description
1	7 data bits, no parity
2	7 data bits, even parity
3	7 data bits, odd parity
4	8 data bits, no parity
5	8 data bits, even parity
6	8 data bits, odd parity

**Parameter 26 Serial Port 2 Baud Rate (1 [9600 baud])**

Enter a baud number from the table below to select a baud rate from the description column. (\*HS baud rates for the 100 samples per sec version only).

Baud Number	Baud Description
1	9600 Baud
2	4800 Baud
3	2400 Baud
4	1200 Baud
5	600 Baud
6	300 Baud (* HS 19.2K)
7	150 Baud (*HS 38.4K)

**Parameter 27 TX2 Control / Station ID (255 [single station])**

Serial Port 2 can be used for continuous transmission of scale data or as a network buss or for single station remote control.

- Enter a 0 to enable continuous transmission of TX 2 data. The data sent is configured in parameter 28 (TX2 Format).
- Enter a station ID (1 to 254) for multi-drop network configuration
- Enter 255 for single station remote control

## Parameter 28 TX2 Format (2 Condec format)

Serial Port 2 can be used for continuous transmission of scale data. The TX2 Format parameter determines what is sent. There are 5 selections:

- 1 - AND: <status>, <mode>, <polarity><weight><units><terminate>  
 Status: OL (overload), ST (stable), US (unstable, in motion)  
 Mode: GS (gross mode), NT (net mode)  
 Polarity: + (positive weight), - (negative weight)  
 Weight: 7 characters data, NOT zero blanked, with decimal point  
 Units: lb, kg, t (ton), tn (tonne), g<sp> (gram), oz  
 Terminate: lf, cr (line feed, carriage return)
- 2 - CONDEC: <st><polarity><weight><units><mode>>status<terminate>  
 Polarity: space (positive weight), - (negative weight)  
 Weight: 7 characters, zero blanked, with decimal point  
 Units: L (lb), K (kg), T (ton), G (gram), O (oz)  
 Mode: G (gross mode), N (net mode)  
 Status: <space> (valid weight), M (motion), O (over wt), I (invalid)  
 Terminate: lf, cr (line feed, carriage return)
- 3 - WEIGHTRONIX: <mode1><mode2><polarity><weight><space><units><term>  
 Mode1: space (gross mode), 0 (zero if net mode)  
 Mode2: G (gross mode), N (net mode)  
 Polarity: + (positive weight), - (negative weight)  
 Weight: 6 characters, NOT zero blanked, with decimal point  
 Units: lb, kg, oz, g <space>(gram), t<space> (ton), tn (tonne)  
 Terminate: lf, cr (line feed, carriage return)
- 4 - OHAS: <polarity><weight><space><units><2 spaces><mode><status><term>  
 Polarity: space (positive weight), - (negative weight)  
 Weight: 7 digits, zero blanked, with decimal point  
 Units: lb, kg, oz, g <space>(gram), t<space> (ton), tn (tonne)  
 Mode: G (gross mode), N (net mode)  
 Status: <space> (valid weight), M (motion), O (over wt), I (invalid)  
 Terminate: lf, cr (line feed, carriage return)
- 5 - Print label 85: transmits the contents of parameter 85 (print label 85)  
 Data entered into a print label can include register data:  
 [253] [reg no] buffer register data, minimum size (zero blanked no spaces)  
 [254] [reg no] buffer data, 7 character field, zero blanked, right justified.

## Printer Parameters

---

The IDS440 provides a universal printer interface for various printers. The printer interface allows you to select and customize the data output for serial or parallel printers. The serial interface option uses Serial Port 1 (TB1) for connection to the printer. The parallel interface uses the TTL I/O Port (TB4) for connection to the printer. Refer to the “HARDWARE INSTALLATION AND WIRING “ section for information on connector pin designations. NOTE: The parallel interface may not be available if the IDS440 is configured to use setpoint outputs.

### Parameter 29 Printer Port Select (2 [Serial Port 1])

Enter a number from the following list to select a printer option:

- 1 Parallel Printer interface.
- 2 Serial Printer interface.

### Parameter 30 Auto Print LF after CR (1 [yes])

Some printers require a line feed character (LF) to advance the paper and some printers advance the paper with only a carriage return character (CR).

- Enter a 1 to automatically add a line feed after a carriage return.
- Enter a 0 to NOT add a line feed after a carriage return.

### Parameter 31 End of Print Character (12 [form feed])

The end of print character is sent to the printer at the end of a print transmission. If your printer requires a special character to release the paper or to form feed the paper, enter the code here. The ASCII chart in the appendix lists the ASCII codes and their numeric values. Enter a 0 (zero) if no end of print character is required.

### Parameters 32, 33 34, 84, 85, 86, 87, 88, 89 and 90 Print Labels

The IDS440 provide 7 programmable print labels. They are available for printing company name, address, station ID, or other messages. Labels 32, 33, and 34 are up to 16 characters long; labels 84 - 90 are up to 30 characters long. Use the ASCII chart in the appendix to look up the numeric values of the ASCII codes. Data entered into a print label can include register data:

- [253] [reg no] buffer register data, minimum size (zero blanked no spaces)
- [254] [reg no] buffer register data, 7 character field, right justified

Or time & date [253][110], time [253][111], date [253][112].

Example: Print "Total [reg 1 data] ton". Select parameter 32 to begin Print Label 1 entry. The display prompts “C0 xxx” where xxx is the current character 0 entry. Enter:

```
84, 111, 116, 97, 108, 32, 254, 1, 32, 116, 111, 110, 13, 0
T o t a l <reg1> t o n <cr>
```

Remember to enter a 0 as the last entry of the print label.



## **Parameters 35, 36, 37, and 38: Print Codes**

The IDS440 provides 4 programmable print codes. The print codes are used to send special setup parameters to the printer, such as select print size or select print font. Each print code is up to 4 characters long. Consult your printer manual for the print codes that you may want to use. Enter the codes in decimal format (an ASCII carriage return = 13). Select parameter 35 to begin print code 1 entry. The IDS440 prompts “C0 XXX” where xxx is the current character 0 print code value. Enter data for character 0. The IDS440 prompts “C1 XXX”. Continue the code entry. Enter a 0 to end print code entry.

## **Parameter 39 Enable TTL Remote Control (1 [enabled])**

Use parameter 39 to enable remote control using TTL inputs 1 thru 4 (TB4 pins 10-13).

Enter a 1 to use TTL inputs 1-4 to activate scale basic functions 1 - 4. For example, grounding TB4 pin 10 (TTL input 1) activates scale basic function 1.

Enter a 0 to disable TTL remote control.

## **Display Intensity, Battery, Watch Dog Timer**

---

### **Parameter 40 Display Intensity (10)**

Use parameter 40 to set the brightness of the IDS440's numeric display and LED indicators. The brightness can be set from 1 (dimkest) to 15 (brightest).

### **Parameter 41 Battery Backup (0 [no])**

The battery is used to preserve the time and date, memory registers, and ID memory when power is lost. Set the Battery Backup parameter to ON (1) to prevent the IDS440 from clearing memory when power is restored, set parameter 41 to OFF (0) to erase memory when power is restored.

### **Parameter 42 Enable Watch Dog Timer (0 [no])**

The watchdog timer resets the IDS440 when the weight display is not updated within the time-out time (0.2 sec). Set the Enable ON (1) to reset after time-out. Set the Enable OFF (0) to turn off the watchdog timer.

## **Parameters 43-50 Fixed Registers**

---

The Fixed Registers are used by the Trip-Level Event Monitor to determine when a trip-level is reached. See the “Scale Basic / Event Monitor” manual for more information. Parameters 43 thru 50 select Fixed Setpoints 1 thru 8. Select the parameter number to be changed and then enter the trip-level weight.

## **Parameters 51-58 Keyboard Event Functions**

---

The keyboard event functions determine what actions take place when a key is pressed. The Power on start function activates a function when power is applied to the indicator.

<b>Number</b>	<b>Parameter Name</b>	<b>Default Value</b>	<b>Password</b>
51	Power on start function	0 (no function executed)	2
52	PRINT key function	136 (Print function)	2
53	UNITS key function	127 (Units toggle function)	2
54	Gross/Net key function	128 (Gross/Net toggle)	2
55	TARE key function	129 (Tare function)	2
56	ZERO key function	130 (Tare function)	2
57	Function Key 1 (F1)	0 (no function executed)	2
58	Function Key 2 (F2)	0 (no function executed)	2

# Parameter Functions

The parameter functions are used to set parameters that are too complex for a single numeric entry. The following table lists the parameter functions:

## Parameter Functions

<b>Fn. No</b>	<b>Function Name</b>	<b>Password Level</b>
59	Display Calibration Audit Number	0
60	Calibrate Scale - deadload first	3
61	Calibrate Scale - span first	3
62	Calibrate Deadload Only	3
63	Adjust Gain Calibration	3
64	Configure Passwords	2
65	Configure Print Formats	2
66	Set Time and Date	2
67	Display Operation Parameters	0
68	Print Operation Parameters	0
69	Diagnostic Tests	0
70	Initialize Operation Parameters to factory defaults.	3
71	Configure Event Monitor	2
72	Function Editor	2&3
73	Initialize Function Memory	2
74	Set Debug mode for Event monitors and Scale basic fns.	2
75	Enable Peak Detect (optional)	2
76	Set debug mode for event monitors and scale basic fns.	2
78	Erase Id Memory	1
79	Enable Multi-point Linearization (default = disabled[0])	3
80	Calibrate using Multi-point Linearization	3
81	Analog output offset (default = 0)	1
82	Analog output span (default = 10,000)	1
83	Analog output register (default = 0 [disabled])	1

The Password Level is used to prevent unauthorized access to parameter functions. See Parameter Function 64, “Configure Passwords”, for more information on passwords.

## **Access Parameter Functions**

---

Hold the CLEAR key down and press the ENTER key. The numeric display prompts “CFG xx” where xx is the currently selected parameter. Enter a parameter function number and then press the ENTER key. NOTE: use the UNITS key (↓) and the PRINT key (↑) to scroll the CFG parameter number. Press the UNITS key to increment the CFG number, press the PRINT key to decrement the CFG number.

To exit configuration and store changes, press the CLEAR key when “CFG xx” is being displayed.

To exit configuration and NOT store changes, enter 999 when “CFG xx” is being displayed. The display prompts “Abort”. Press the ENTER key to abort (exit without saving changes) or press the CLEAR key if you do not want to abort.

### **Example: Begin Calibration of the Scale-**

The IDS440 is in the display weight mode. Hold the CLEAR key down and press the ENTER key to enter the configure mode. The IDS440 prompts “CFG xx” where xx is the last selected parameter. Enter 60 and then press the ENTER key. The IDS440 prompts “dEAdld”. Begin the calibration process or press the CLEAR key to exit.

## **Function 59 Display Calibration Audit Number.**

---

Use function 59 to view the audit and configuration numbers, the software ID number, and the status of the internal function lock.

The IDS440 provides a calibration audit number and a configuration number. They are used to indicate changes to calibration data and configuration data and can be used in place of mechanical seals by some regulatory agencies. The IDS440 audit number increments each time a calibration parameter is changed (deadload or weight conversion factor). The configuration number increments each time a password level 3 parameter is changed. If physical seals are used, then place the internal function lock in the locked position before sealing. Calibration and password level 3 parameters cannot be accessed when the function lock is in the locked position.

1. Hold the CLEAR key down and press the ENTER key to enter the configure mode.
2. Enter CFG 59. The IDS440 prompts “A xxxx” where xxxx is the audit number.
3. Press the ENTER key. The IDS440 prompts “C xxxx” where xxxx is the current calibration number.
4. Press the ENTER key. The IDS440 prompts “bixxxx” where bixxxx is the ID number of the software installed in the IDS440.
5. Press the ENTER key. The IDS440 prompt “un-LoC” if the function lock is in the unlocked position, or “Loc Ed” if the function is in the locked position.

## **Function 60 Calibrate Scale - Deadload First**

---

Use function 60 to calibrate the scale by reading the deadload first and then reading the span. Set the Scale Operation Parameters before using function 60. Best results are obtained when the IDS440 and load cells have reached thermal equilibrium (power applied for approximately 30 to 120 minutes depending on load cell size). NOTE: function 60 automatically adjusts parameter 19 (deadload offset).

Hold the CLEAR key down and press the ENTER key to enter the configure mode.

1. Enter CFG 60. The IDS440 prompts “dEAdld”. Remove all weight from the scale. Press the ENTER key. The IDS440 reads the scale’s deadload weight. NOTE: press the CONTINUE key (Units) to skip deadload read.
2. The IDS440 display alternates between “CALib” and the weight on the scale. Place the calibration weight on the scale. Enter the calibration weight using the numeric keypad. Press the ENTER key. The IDS440 reads the calibration weight. If an error is made in data entry, press the PRINT (↑) key to re-enter the calibration weight.
3. The IDS440 prompts “CFG 60”. Press the CLEAR key to exit the configure mode.

## **Function 61 Calibrate Scale - Span First**

---

Use function 61 to calibrate the scale by reading the span first and then reading the deadload. Set the Scale Operation Parameters before using function 61. Best results are obtained when the IDS440 and load cells have reached thermal equilibrium (power applied for approximately 30 to 120 minutes depending on load cell size).

1. Hold the CLEAR key down and press the ENTER key to enter the configure mode.
2. Enter CFG 61. The IDS440 display alternates between “CALib” and the weight on the scale. Place the calibration weight on the scale. Enter the calibration weight and press the ENTER key. The IDS440 reads the calibration weight.
3. The IDS440 prompts “dEAdld”. Remove all weight from the scale. Press the ENTER key. The IDS440 reads the scale’s deadload weight.
4. The IDS440 prompts “CFG 61”. Press the CLEAR key to exit the configure mode.

## **Function 62 Calibrate Deadload Only**

---

Use function 62 to re-calibrate the deadload weight without affecting the span calibration.

1. Hold the CLEAR key down and press the ENTER key to enter the configure mode.
2. Enter CFG 62. The IDS440 prompts “dEAdld”. Remove all weight from the scale. Press the ENTER key. The IDS440 reads the scale’s deadload weight.
3. The IDS440 prompts “CFG 62”. Press the CLEAR key to exit the configure mode.

## Function 63 Adjust Gain Calibration

---

Use function 63 to make small adjustments to the span calibration factor. Zero the scale and then place a known weight on the scale.

1. Hold the CLEAR key down and press the ENTER key to enter the configure mode.
2. Enter CFG 63. The IDS440 displays the weight on the scale along with a center of digit indication in the least significant digit position of the display (the minus sign (-) indicates the center of digit.
3. Press the '1' key to adjust by 1, press the '2' key to adjust by 10, the '3' key to adjust by 100, or the 4 key to adjust by 1000. Use the UNITS key (↓) and the PRINT key (↑) to increase or decrease the displayed weight until the displayed weight is the same as the weight on the scale. The center of digit indicator (-) should be displayed for maximum accuracy.
4. Press the CLEAR key to exit Adjust Gain procedure.

## Adjust Gain – 5 Point Linearization

If 5 point Linearization is enabled, the gain adjust procedure begins with the display alternating between the calibration number (example: Cal 1) and the calibration weight.

- Press the ENTER key to adjust the gain at the displayed calibration point.
- Press the UNITS key (↓) to adjust the next calibration point
- Press the PRINT key (↑) adjust the previous calibration point.
- Press the ZERO key to clear a calibration point. (Must re-calibrate to reuse).

## Function 64 Configure Passwords

---

Use function 64 to enter password data. The IDS440 provides two security passwords that can be activated and entered to protect configuration data. Password 1 is used to protect I/O port configuration, setpoint, and event monitor data. Password 2 is used to protect calibration and scale configuration data. Security level 3 provides extra protection for password level 2 data. Security level 3 requires the entry of password 2 and the Function Lock inside the IDS440 to be in the unlocked position. Password 3 will inhibit viewing, changing, and uploading of Scale Basic functions to a PC when password is active but will allow downloading a new Scale Basic program from the PC to the indicator. All passwords will be disabled once the new program has been downloaded into the indicator and should be reactivated.

The Operation Parameter Reference Table lists the configuration parameters and the password/security level required to access them. The IDS440 prompts "PASS 1" when a parameter is selected that requires password level 1. If the entered password is incorrect, the IDS440 displays "Error". Press the ENTER key to try again. Press the CLEAR to exit from password entry.

**IMPORTANT NOTE:** Write down the passwords and put them in a safe place. If you loose and forget a password, there is no way to access the protected functions.

1. Hold the CLEAR key down and press the ENTER key to enter the configure mode.
2. Enter CFG 64. The IDS440 prompts "P1 xxxx" where xxxx is the current password number. Enter a new password number or press the ENTER key to use the displayed number. Enter a 0 (zero) for the password number to disable the password.
3. The IDS440 prompts "P2 xxxx". Enter password 2 data.
4. The IDS440 prompts "P3 xxxx". Enter password 3 data.

## Function 65 Configure Print Formats

---

Use function 65 to modify print formats to meet your print requirements. The print formats are grouped into PAGES that are used for generating print data onto a form. Each page is organized into rows and columns as follows:

Line No.	Column No.	Item No.

Line No. = Line number on the page to print the item on.

Column No. = Column position where item print begins.

Item No. = Item to print.

Print format design requires you to become familiar with the PAGE LIST and the PRINT ITEM LIST. The PAGE LIST describes how each PAGE is used. The PRINT ITEM LIST describes what ITEMS can be included in each page. Use the print format worksheets to design new print formats. The PRINT FORMAT DESIGN EXAMPLE illustrates how a print format is designed. A list of the default print formats is found in DEFAULT PRINT FORMATS. The print formats (PAGES) are initialized to factory settings when the Initialize System Parameters function is used. (parameter function 73).

### Modify or Design a Print Format

1. Hold the CLEAR key down and press the ENTER key to enter the configure mode. Enter CFG number 65.
2. The IDS440 prompts "PAGE". Enter the Page number that you want to modify.
3. The IDS440 prompts "Px E1" where x is the page number that you entered and E1 indicates that the current entry being modified is entry 1. Press the ENTER key.
4. The IDS440 prompts "L x" where x is the line number on the page that entry 1 is to print on. Enter a new line number or press ENTER to use the displayed number.
5. The IDS440 prompts "C x" where x is the column number on the page that entry 1 is to print on. Enter a new column number or press ENTER to use the displayed number.
6. The IDS440 prompts "i x" where x is the item number that is to be printed. (See Print Item List for a description of items that can be printed). Enter a new item number or press the ENTER key to use the displayed number.
7. The IDS440 prompts "Px E2". Use the procedure above to modify entry 2. Use the UNITS key (↓) to scroll forward in the page table, use the PRINT key (↑) to scroll backwards.
8. Enter a zero (0) for the line number (L 0) after the last entry that is to be printed. Press the CLEAR key to exit from the current page. NOTE: if the 16<sup>th</sup> entry is used, then a zero entry for the line number is not necessary.



**Page List**

FORMAT	DESCRIPTION
PAGE 1	Prints when the IDS440 is in the GROSS weight mode.
PAGE 2	Prints when the IDS440 is in the NET weight mode.
PAGE 3	Used by Scale Basic functions when needed.
PAGE 4	Used by Scale Basic functions when needed.

**Print Item List**

Item #	Description
2-4	Print Label 1, 2, and 3 (see chap. 5: Set I/O Port, parameters 32-34)
84-90	Print Labels 4 thru 10. (Parameters 84-90)
5	Gross Weight (primary units)
6	Tare Weight (primary units)
7	Net Weight (primary units)
8	Gross Weight labeled "WEIGHT" (primary units)
9	Scale Status (used by continuous transmit)
10	Time and Date (battery/time & date option required)
11	Time (battery/time & date option required)
12	Date (battery/time & date option required)
15	Gross Weight (alternate units)
16	Tare Weight (alternate units)
17	Net Weight (alternate units)
18	The Displayed weight (in the displayed units and mode)
21	Print Code 1 (see section: <b>Set I/O Port Parameters</b> , params 35-38)
22	Print Code 2
23	Print Code 3
24	Print Code 4
25	Gross Weight (display units)
26	Tare Weight (display units)
27	Net Weight (display units)
32	Space holder, does nothing.
33	Form Feed (ASCII 12)
34	Carriage Return (ASCII 13)
35	Line Feed (ASCII 10)
40	ID number
41	ID total (ID register 1)
42-46	ID registers 2 through 6
51-66	Memory registers 1 through 16
84-90	Print Labels 84 to 90 (see parameters 84 to 90)

**Print Format Design Example**

EXAMPLE PRINT:

	1111111111222222222233333333334
COLUMN	1234567890123456789012345678901234567890
LINE	
1	
2	
3	GROSS 54785 LB
4	TARE 12451 LB
5	NET 42243 LB
6	
7	TIME 03:45 PM DATE 05 AUG 1999

EXAMPLE FORMAT DESIGN WORKSHEET:

Page:1	Item Description	Line No.	Column	Item No.
E1	Gross Weight	3	4	5
E2	Tare Weight	4	4	6
E3	Net Weight	5	4	7
E4	Time and Date	7	1	10
E5	End of Print	0	0	0

NOTE: A zero in the Line No column terminates printing. Use zero only after all required information has been entered. The maximum number of entries is 16. If the 16<sup>th</sup> entry is used, a line number 0 is not required.

**Default Print Formats**

The print formats (PAGES) are initialized to the following factory settings when the IDS440 is initialized.

Page 1	Item Description	Line No.	Column	Item No.
E1	The Displayed Weight	1	1	18
E2	End of Print	0	0	0

Page 2	Item Description	Line No.	Column	Item No.
E1	Gross Wt. (primary units)	3	5	5
E2	Tare Weight (primary units)	4	5	6
E3	Net Weight (primary units)	5	5	7
E4	End of Print	0	0	0

**Format Design Worksheets**

<b>Page</b>	<b>Item Description</b>	<b>Line No.</b>	<b>Column</b>	<b>Item No.</b>
E1				
E2				
E3				
E4				
E5				
E6				
E7				
E8				
E9				
E10				
E11				
E12				
E13				
E14				
E15				
E16				

<b>Page</b>	<b>Item Description</b>	<b>Line No.</b>	<b>Column</b>	<b>Item No.</b>
E1				
E2				
E3				
E4				
E5				
E6				
E7				
E8				
E9				
E10				
E11				
E12				
E13				
E14				
E15				
E16				

## **Function 66 Set Time and Date**

---

Use function 66 to set the time and date. Entering 19 can display the time and date when the meter is in the idle mode. Date will be printed in a Y2K compliant four-digit year.

1. Hold the CLEAR key down and press the ENTER key to enter the configure mode.
2. Enter CFG 66. The IDS440 prompts “t”. Enter the time using 5 digits. The last digit should be 0 for AM, 1 for PM, or 2 for 24-hour time.
3. The IDS440 prompts “D”. Enter the date using 6 digits in the format MMDDYY.

## **Function 67 Display Operation Parameters**

---

Use function 67 to view operation parameters. This function allows viewing the parameters when the password is not available.

1. Hold the CLEAR key down and press the ENTER key to enter the configure mode.
2. Enter CFG 67. The IDS440 prompts “PAR xx” where xx is the currently selected parameter number. Press the ENTER key to view the parameter data or enter a parameter number to view.
3. Press the CLEAR key to exit function 67.

## **Function 68 Print Operation Parameters**

---

1. Hold the CLEAR key down and press the ENTER key to enter the configure mode.
2. Enter CFG 68. The IDS440 prompts “Print”. Press the ENTER key to print the operation parameters or press the CLEAR key to exit without printing.

## Function 69 Diagnostic Tests

---

1. Hold the CLEAR key down and press the ENTER key to enter the configure mode.
2. Enter CFG 69. The IDS440 prompts “diA xx” where xx is the currently selected test number. Enter a test number or press the ENTER key to use the displayed number.
3. The IDS440 begins the selected test. Press the CLEAR key when the test is complete.

Test #	Hardware Tested	Description
1	Serial Com. Port 1	Display input data.
2	Serial Com. Port 1	Display input error count.
3	Serial Com. Port 1	Transmit data.
4	Serial Com. Port 2	Display input data.
5	Serial Com. Port 2	Display input error count.
6	Serial Com. Port 2	Transmit data.
7	Parallel Port	Transmit data.
8	A/D converter	Display raw conversion data.
9	Ram Memory	Test memory for errors.
10	Display	Turn on all LED's and display segments.
11	Configuration	Print the EAROM configuration data.
12	Serial Com. Port 1	Transmit/Receive loop-back test.
13	Serial Com. Port 2	Transmit/Receive loop-back test.

See section: **Diagnostic Tests** for more information on each test.

## Function 70 Initialize Operation Parameters to Factory Defaults

---

Use function 70 to reset the IDS440's operation parameters to their factory default values. This function is used to reset the IDS440's earom when a new EPROM program is installed. Do NOT use this function unless you are ready to begin installation from the beginning.

1. Hold the CLEAR key down and press the ENTER key to enter the configure mode.
2. Enter CFG 70. The IDS440 prompts, “rESEt”. Press the ENTER key to reset operation parameters or press the CLEAR key to exit without changing the operation parameters.
3. **NOTE:** enter 10809 when the display prompts, “rESEt” to reset the calibration factors to the factory defaults.

## **Function 71 Configure Event Monitor**

---

Use function 71 to enter setpoint data into the Event Monitor. See the “Scale Basic / Event Monitor” manual” for more information on the event monitor parameters.

1. Hold the CLEAR key down and press the ENTER key to enter the configure mode.
2. Enter CFG 71. The IDS440 prompts “Eno”. Enter the Event number to be modified.
3. The IDS440 prompts “P0 xx” where P0 is parameter 0 and xx is the current value of parameter 0. Enter new data for P0 or press the ENTER key to use the displayed data.
4. Use the UNITS key (↓) or the PRINT key (↑) to scroll through the parameter numbers. Press the CLEAR key to exit from the current Event number. Press the CLEAR key again to exit from event monitor data entry.

## **Function 72 Scale Basic Function Editor**

---

Use function 72 to create or modify Scale Basic functions. See the “Scale Basic / Event Monitor” manual for more information on Scale Basic functions.

1. Hold the CLEAR key down and press the ENTER key to enter the configure mode.
2. Enter CFG 72. The IDS440 prompts “Fn”. Enter the function number to be modified.
3. The IDS440 prompts “0- xxx” where 0- is entry zero, and xxx is the current value for entry zero. Enter new data for 0- or press the ENTER key to use the displayed data.
4. Use the UNITS key (↓) or the PRINT key (↑) to scroll through the entry numbers. Press the CLEAR key to exit from the Function Editor.

## **Function 73 Initialize Function Memory**

---

The initialize function erases function memory and setpoint monitor memory, and initializes all parameters with password level 1 or 2.

Function 73 prompts “rs Fn” . Press the Enter key to initialize only or enter a number below to activate a built in program.

1. Fill to Setpoint.
2. Checkweigh: Over/Between/Under
3. Weigh-in / Weigh-out
4. Axle Weigh – Short Scale
5. Axle Weigh – Long Scale
6. ID Tare and Total
7. Peak Hold

## **Function 74 Configure Timers**

---

The display prompts “tr” when function 74 is activated. Enter the timer number to be modified (1 to 5) then press the ENTER key. The first parameter (L) is the time length in tenths of a second. The second parameter (Fn) is the function number to be executed when the timer times out.

## **Parameter 75 Enable Peak Detect**

---

Enter a 1 to enable peak detect, enter a 0 to disable peak detect.

## **Parameter 76 Debug mode for Event monitors and Scale Basic**

---

The Debug mode is used to ‘debug’ event monitors and scale basic functions. Enter a 1 to activate debug mode, enter a 0 to disable debug mode. When debug mode is enabled Scale Basic functions ‘single step’. The subroutine stack level and the Function number are displayed when entering a function. Example: “0 F12”. Press the ENTER key to begin execution of the function. The instruction address and instruction code are displayed. Example: “21 255”. Continue to press the ENTER key to step thru the program. NOTE: the first step displayed for all scale basic functions is a GOTO (244).

## **Function 78 Initialize ID memory**

---

Use function 78 to initialize id memory after it has been corrupted. The ID memory becomes corrupted when power is lost (when battery backup is disabled) or when the battery is allowed to discharge below 2 volts.

## **Parameter 79 Enable Multi-point Linearization**

---

Enter a to 1 to enable multi-point Linearization, enter a to 0 to disable multi-point Linearization. The IDS 440 uses the calibration factors set in function 80 below when multi-point Linearization is enabled.

## **Function 80 Calibrate - Multi-point Linearization**

---

Use function 80 to calibrate the scale using up to 5 calibration points to 'linearize' the load cell. Set the Scale Operation Parameters before using function 80. Best results are obtained when the IDS 440 and load cells have reached thermal equilibrium (power applied for approximately 30 to 120 minutes depending on load cell size). NOTE: function 80 automatically adjusts parameter 19 (deadload offset).

1. Hold the CLEAR key down and press the ENTER key to enter the configure mode.
  2. Enter CFG 80. The IDS 440 prompts "dEAdld". Remove all weight from the scale. Press the ENTER key to obtain the deadload weight. Press the Units key (↓) to continue without reading a new deadload weight.
  3. The IDS 440 's display alternates between "CAL 1" and the weight on the scale. Place the first calibration weight on the scale. Enter the calibration weight using the numeric keypad. Press the ENTER key. The IDS 440 reads the calibration weight.
  4. The IDS 440 's display alternates between "CAL 2" and the weight on the scale. Repeat step 3. The IDS 440 will accept up to 5 calibration points. Press the CLEAR key to complete calibration if less than 5 calibration points are used.
  5. The IDS 440 prompts "CFG 80". Press the CLEAR key to exit the configure mode
- Parameter 79 must be set to 1 to enable the IDS440 to use the multi-point Linearization calibration parameters.
  - Use the UNITS key (↓) to continue to the next calibration point if the current point has already been calibrated.



# Diagnostic Tests

---

The DIAGNOSTIC TESTS are accessed using configuration function 69. Hold the CLEAR key down and press the ENTER key. The display prompts “CFG xx” where xx is the currently selected parameter. Enter 69 and press the ENTER key to access the DIAGNOSTIC TESTS.

The display prompts “diA xx” where xx is the last selected diagnostic function. Select a test number from the table below. Enter the test number and press the ENTER key.

**Table of Diagnostic Tests**

---

Test No.	Hardware Tested	Description
1	Serial Com. Port 1	Display input data.
2	Serial Com. Port 1	Display input error count.
3	Serial Com. Port 1	Transmit data.
4	Serial Com. Port 2	Display input data.
5	Serial Com. Port 2	Display input error count.
6	Serial Com. Port 2	Transmit data.
7	Parallel Port	Transmit data.
8	A/D converter	Display raw conversion data.
9	Ram Memory	Test memory for errors.
10	Display	Turn on all LED's and display segments.
11	Configuration	Print the EAROM configuration data.
12	Serial Com. Port 1	Transmit/Receive loop-back test.
13	Serial Com. Port 2	Transmit/Receive loop-back test.

### **Diagnostic Test 1: Serial Com Port 1 - Display Input Data**

---

This test displays serial data as it is received by serial communications port 1. The numeric display has limited alpha display capability, however numeric and some alpha characters are legible. If all data being received is unintelligible, the baud rate is probably incorrect. If nothing is displayed on the display, then check the following:

1. RS232/Current loop switch on the main circuit board.
2. Cabling between the communicating units.
3. Make sure the sending unit is actually sending data.

Press the CLEAR key to exit diagnostic test 1.

### **Diagnostic Test 2: Serial Com Port 1 – Display Errors**

---

This test displays the number of framing and parity errors that are detected in the input data stream. The error count is set to zero when entering this test. New errors are displayed as “PxxFxx” where Pxx is the number of parity errors and Fxx is the number of framing errors. If the error count exceeds 99, the display will remain at 99.

Press the CLEAR key to exit Diagnostic test 2.

### **Diagnostic Test 3: Serial Com Port 1 - Transmit Data**

---

This test transmits data out of serial communications port 1. The display prompts: “OUT 0”. Press the ENTER key to send data. Serial Port 1 transmits “1234567890ABCDEF” and prompts “OUT 1” to indicate that 1 transmission has occurred. Press the ENTER key again or press the CLEAR key to exit diagnostic test 3.

NOTE: If the error message “Er CtS” appears, the data cannot be transmitted because the handshake signal, clear-to-send (TB1 pin 7), is low or not connected. If clear-to-send is not used jumper it to data-terminal-ready (TB1 pin 4)

### **Diagnostic Test 4: Serial Com Port 2 - Display Input Data**

---

This test displays serial data as it is received by serial communications port 2. The numeric display has limited alpha display capability, however numeric and some alpha characters are legible. If all data being received is unintelligible, the baud rate is probably incorrect. If nothing is displayed on the display, then check the following:

1. RS232/RS485 jumper on the main circuit board.
2. Cabling between the communicating units.
3. Make sure the sending unit is actually sending data.

Press the CLEAR key to exit diagnostic test 4.

### **Diagnostic Test 5: Serial Com Port 2 – Display Errors**

---

This test displays the number of framing and parity errors that are detected in the input data stream. The error count is set to zero when entering this test. New errors are displayed as “PxxFxx” where Pxx is the number of parity errors and Fxx is the number of framing errors. If the error count exceeds 99, the display will remain at 99.

Press the CLEAR key to exit Diagnostic test 5.

### **Diagnostic Test 6: Serial Com Port 2 - Transmit Data**

---

This test transmits data out of serial communications port 2. The display prompts: “OUT 0”. Press the ENTER key to send data. Serial Port 2 transmits “1234567890ABCDEF” and prompts “OUT 1” to indicate that 1 transmission has occurred. Press the ENTER key again or press the CLEAR key to exit diagnostic test 6.

### **Diagnostic Test 7: Test parallel output**

---

This test transmits data out the parallel TTL I/O port. The display prompts: “dAtA”. Use the numeric keyboard to enter data. Press the ENTER key to transmit the data. If the data is successfully sent, “1= xxx” is displayed, where xxx is the first 3 characters of the data sent and 1= is the number of times that the data has been sent. Press the ENTER key to send the data again. Press the CLEAR key for the “dAtA” prompt. Enter new data to transmit or press the CLEAR key to exit diagnostic test 3.

If the data is not successfully sent, the display will remain blank. If data is not sent within 15 seconds, “Err 13” is displayed. Press the CLEAR key to exit from the error display. The data will not transmit if the BUSY signal (TB4 pin 14) is active (TTL high). Check the cable connections and the sending device.

## **Diagnostic Test 8: Test A/D**

---

This test displays the (filtered) raw data being read from the A/D converter. Use this test to determine optimum deadload and gain settings. If the number displayed at deadload is less than 1000 or greater than 250,000 then use the deadload offset (parameter 19) to add or subtract deadload from the signal input. NOTE: deadload offset is automatically set using the calibration function 60. If the full-scale number displayed is less than 380,000 then use the “loadcell mv/V” parameter 1 to increase the gain. If the full-scale signal is greater than 1,000,000 then use the “loadcell mv/V” parameter 1 to decrease the gain.

If no data is being displayed, the A/D converter is “locked up”. Turn power off and then on and re-activate the test. Check load cell wiring for reversed signal or excitation signals.

Press the PRINT key to scroll the AD test function from:

1. Display raw data (digital filter on).
2. Display and transmit via serial port 2, raw data (digital filter off).
3. Display A/D drift factor. Press the ENTER key to clear the drift factor to 0.

Press the CLEAR key to exit AD test.

## **Diagnostic Test 9: Perform internal memory test**

---

This test writes data to memory and then reads it back to test for failed memory locations. The existing data in memory is not affected by this test. The display prompts, “r TEST” while the test is in progress. The display prompts “PAS 32” if the test is successful. If an error is detected the “Exxxx” is displayed, where xxxx is the location of the error.

## **Diagnostic Test 10: Lamp Test**

---

This test turns on all the LED displays and numeric display segments. Replace any LED or display that does not illuminate. Press the CLEAR key to exit diagnostic test 10.

## **Diagnostic Test 11: Print the EAROM Configuration Table**

---

This function sends the contents to the EAROM configuration memory to the printer. Use this function to document your setup of the when installation is complete.

## **Diagnostic Tests 12 & 13: Loop Back Tests**

---

These tests are used by the factory to test the serial ports transmit and receive functions. Transmit and receive lines must be jumpered together and the clear-to-send must be jumpered to data-terminal-ready for this test.

# Troubleshooting

The following table describes the probable causes to some problems you may encounter. Most problems can be resolved by using the information provided in the table.

## Problems And Probable Causes

Problem	Probable Causes
Printer does not print (serial RS232)	<ul style="list-style-type: none"> <li>* Cable connection problem or invalid pin connections.</li> <li>* Baud rate and format on serial port 1 does not match printer. Printer is not ready or it is busy. Check CTS signal TB1 pin 7. This signal must be high in order to transmit. Jumper pin 8 of TB1 to pin 7 of TB1 CTS/RTS.</li> <li>* Transmitter/receiver IC damaged (U6 MC145406).</li> </ul>
Continuous output does not update	<ul style="list-style-type: none"> <li>* “TX CONTINUOUS” disabled (configuration Parameter 28)</li> <li>* Cable connection problem or invalid pin connections.</li> <li>* Baud rate and format on serial port 2 does not match receiver.</li> <li>* Transmitter/receiver IC damaged (U6 MC145406).</li> </ul>
Input port 1 not working	<ul style="list-style-type: none"> <li>* Baud rate and format on serial port 1 does not match host.</li> <li>* Cable connection problem or invalid pin connections.</li> <li>* Internal switch SW1 (CL/RS232) not set properly for input type.</li> <li>* RS232 transmitter/receiver IC damaged (U6 MC145406).</li> <li>* Current loop receiver IC damaged (U3 4N36).</li> </ul>
Input port 2 not working	<ul style="list-style-type: none"> <li>* Baud rate and format on serial port 2 does not match host.</li> <li>* Cable connection problem or invalid pin connections.</li> <li>* Internal jumper JP3 (RS232/422/485) not set properly.</li> <li>* RS232 transmitter/receiver IC damaged (U6 MC145406).</li> <li>* RS422/485 transmitter/receiver IC damaged (RS422 {U10 75176} RS485 {U14 75176}).</li> </ul>
“Er CtS” error message.	<ul style="list-style-type: none"> <li>* Cable connection problem. Check CTS signal TB1 pin 7. This signal must be high in order to transmit. Jumper to pin 8 of TB1.</li> <li>* Printer is not ready or it is busy.</li> <li>* Transmitter/receiver IC damaged (U6 - MC145406).</li> </ul>
“Err 13” error message (Printer Error)	<ul style="list-style-type: none"> <li>* This error occurs when the parallel output has been selected for printing and the printer is busy, a printer fault has occurred, or there is a problem with the cable.</li> </ul>
Invalid weight display or weight fluctuating	<ul style="list-style-type: none"> <li>* Invalid calibration parameters.</li> <li>* Load cell or load cell input cable problems.</li> </ul>

## Error Messages

---

<b>Error</b>	<b>Description</b>
Err 0	Power on zero error. See parameter 20.
Err 1	Keyboard error. Occurs during power up while a key on the keyboard is being pressed or one of the remote switch inputs is activated.
Err 2	Restart Trap. The microprocessor accessed nonexistent memory location. Usual cause is A/C power “glitch” or static electric discharge.
Err 3	Watchdog Time-out. The weight display has not been updated within the watchdog time-out period. Usual cause is A/C power glitch or static electric discharge.
Err 4	Battery Error. Battery voltage level was below 2 V when the IDS 440 was powered off.
Err 5	Earom memory error. A checksum error has occurred when reading the configuration earom memory. Check calibration parameters and rewrite the earom memory. If error continues, replace earom (U13)
Err 5.1	Earom Time-out, unable to write to the earom memory.
Err 6	Ram memory error. A ram memory error has occurred. Replace U8 if error continues.
Err 7	The A/D converter is “locked up”. Check load cell wiring.
Err 8	Negative deadload error.
Err 9	Count-by error. The entered value is outside the scale count-by set during calibration.
Err 10	Pushbutton ZERO error.
Err 11	A to D converter not working.
Err 12	Negative deadload. Check loadcell wiring. Enter a deadload offset in configuration parameter 19.
Err 13	Printer busy error. The busy signal (TB4 pin 14) is active (+5v TTL hi).
Err 14	Page Format line length error. The page format output exceeded the maximum line length.
Err 15	The function selected is locked. Switch 2 on the IDS 440’s circuit board locks and unlocks configuration parameters.
Err 16	Scale Basic Stack Overflow.
Err 18	Referenced an invalid function instruction.
Err 21	ID not found.
Err 22	Scale Basic Prompt error.
Err 23	ID memory full.
Error OL	Calibration error or scale is over-loaded (above scale capacity).
undEr	Calibration error or scale is under-loaded (below readable weight).

# Hardware and Wiring

This section describes installation and wiring information for the interface ports. There are two bi-directional serial ports, one parallel port with TTL inputs and outputs, and one load cell input port. The serial ports are used to interface to a printer and to a host device or PC for continuous output. The parallel port is used to interface to parallel printers and for remote switch input and relay control using the TTL I/O. The load cell input is used to interface to the scale platform.

## Load Cell Connector - TB3

NOTE: JP1 and JP2 on the circuit board can be used to disable remote sensing.

### Load Cell - TB3

Pin #	Signal Name
1	+ Signal
2	- Signal
3	+ Excitation
4	+ Sense
5	- Sense
6	- Excitation
7	Analog ground

Place jumpers as shown to DISABLE remote sense. Move jumpers up to enable remote sense.

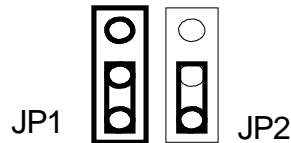

Remote Sense Jumpers - Remote sense DISABLED

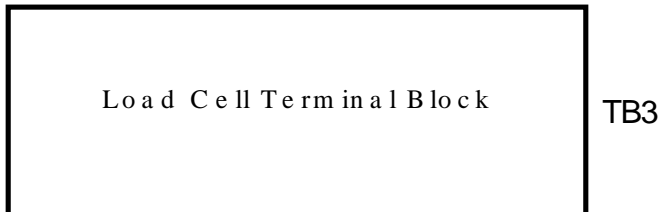

## **Serial Port 1 Connector - TB 1**

---

For RS232 input, set switch S1 to RS232 position, and for current loop input, set the switch to CL position. **NOTE:** Jumper pin 7 CTS to 8 RTS if unit locks up on “Print”.

**Serial Port 1 - TB1**

<b>Pin #</b>	<b>Signal Name</b>
1	+5V
2	RS232 TXD (transmit data)
3	RS232 RXD (receive data))
4	DTR (220 ohm to +5V)
5	Ground (GND)
6	Current Loop Transmit
7	RS232 CTS (busy)
8	RS232 RTS (request to send)
9	Current Loop Input -
10	Current Loop Input +

## **Serial Port 2 Connector - TB 2**

---

For RS232 or RS422/RS485 jumper JP3 input jumper to correct setting.

**Serial Port 2 - TB2**

<b>Pin #</b>	<b>Signal Name</b>
1	+5V
2	RS232 TXD (transmit data)
3	RS232 RXD (receive data)
4	DTR (220 ohm to +5V)
5	Ground (GND)
6	Current Loop Transmit
7	RS485 Transmit -
8	RS485 Transmit +
9	RS485 Receive -
10	RS485 Receive +



## **TTL I/O Port Connector - TB 4**

---

TTL outputs 1 thru 8 will drive 24ma at TTL low level, and 8ma at TTL hi level. Output 9 is an open collector output with 4.7k-ohm resistor to +5V.

**TTL I/O - TB 4**

<b>Pin #</b>	<b>Signal Name</b>
1	TTL Output 1 (Printer Data 1)
2	TTL Output 2 (Printer Data 2)
3	TTL Output 3 (Printer Data 3)
4	TTL Output 4 (Printer Data 4)
5	TTL Output 5 (Printer Data 5)
6	TTL Output 6 (Printer Data 6)
7	TTL Output 7 (Printer Data 7)
8	TTL Output 8 (Printer Data 8)
9	TTL Output 9 (Printer Strobe -)
10	TTL Input 1 (Scale Basic Fn 1)
11	TTL Input 2 (Scale Basic Fn 2)
12	TTL Input 3 (Scale Basic Fn 3)
13	TTL Input 4 (Scale Basic Fn 4)
14	TTL Input 5 (Printer Busy +)
15	TTL Input 6 (Printer Error)
16	Ground (GND)

## P.C. Board Diagram - Connectors, Jumpers, and Switches

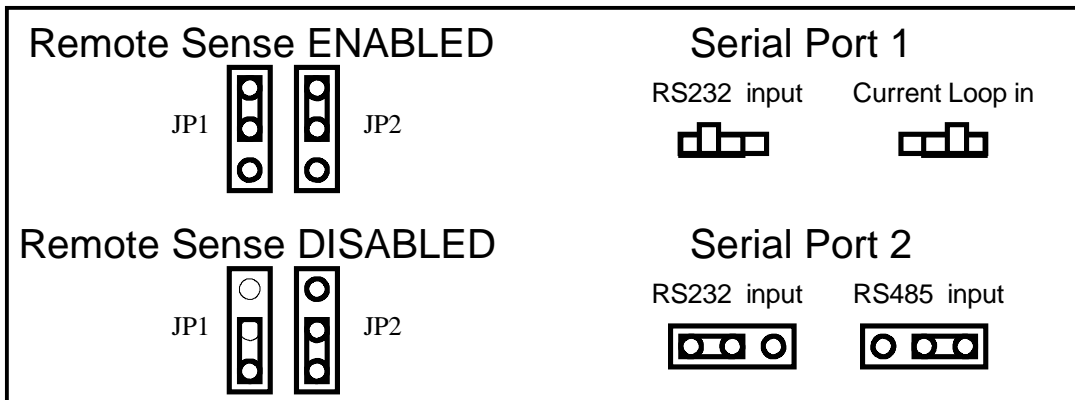
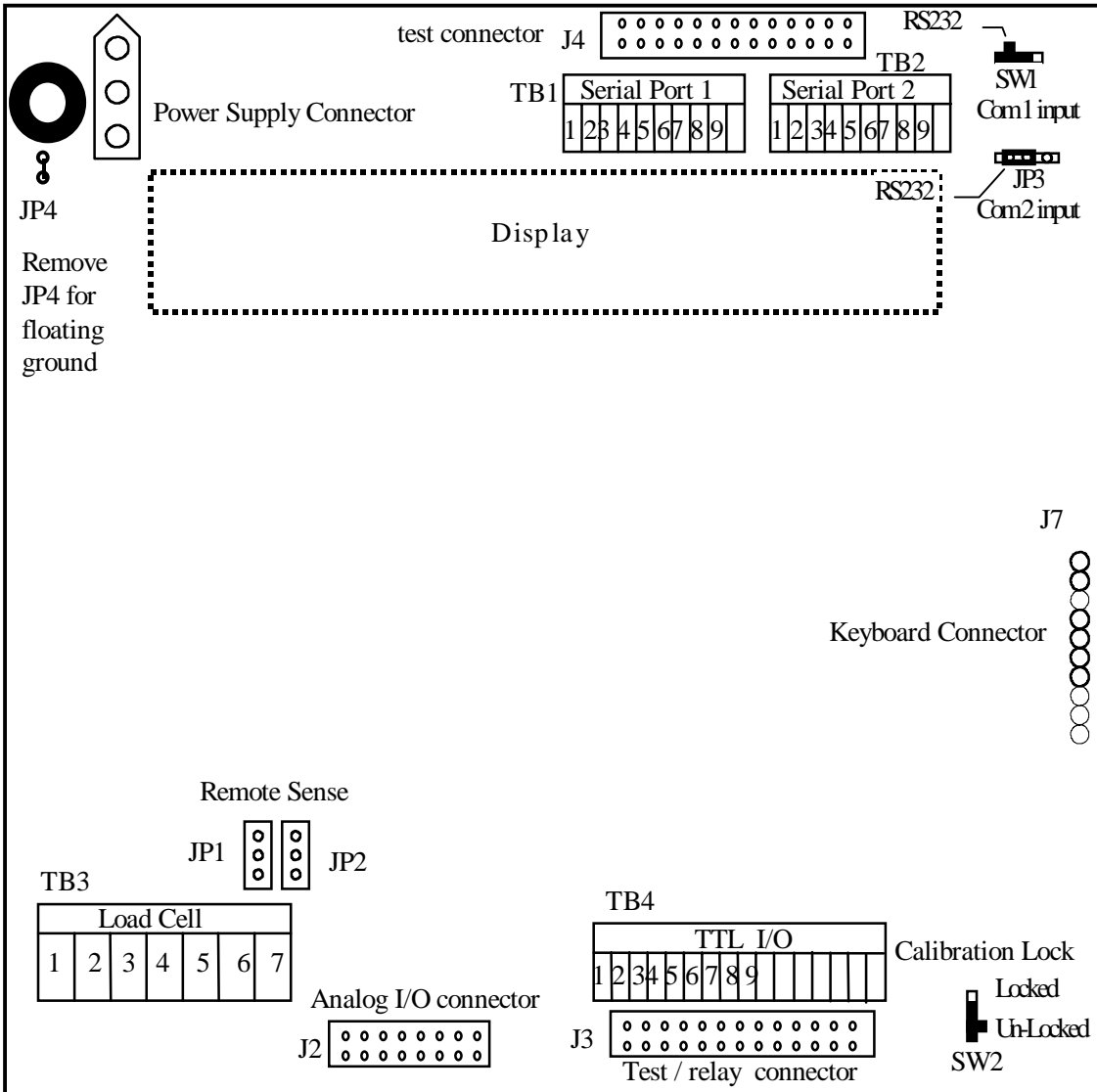

## Sample Cable Drawings

### Load Cell

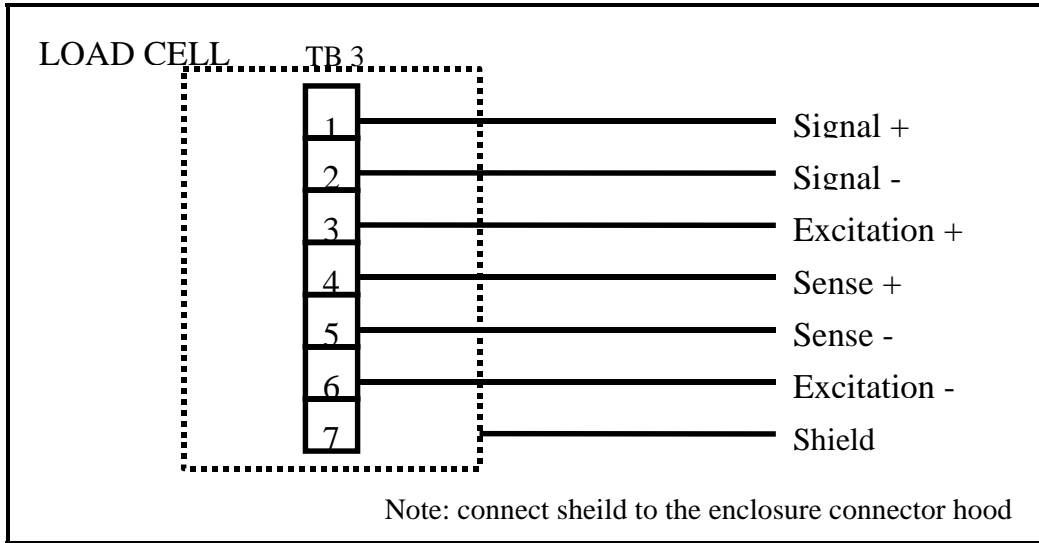

### IDS150A/152/160/320

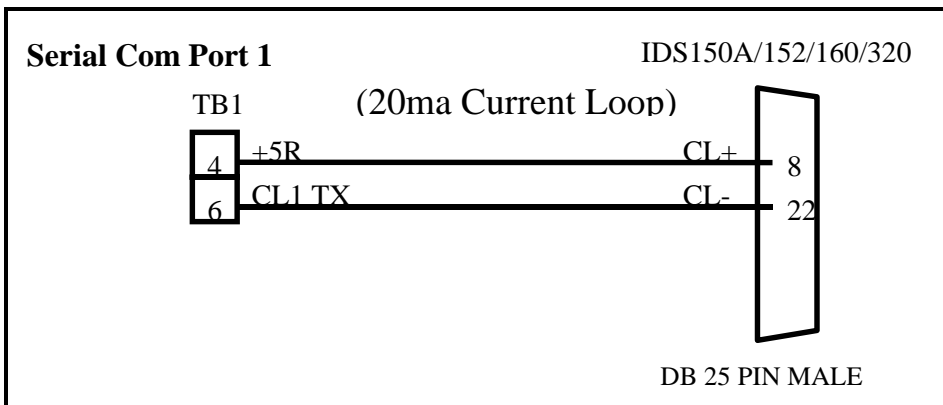
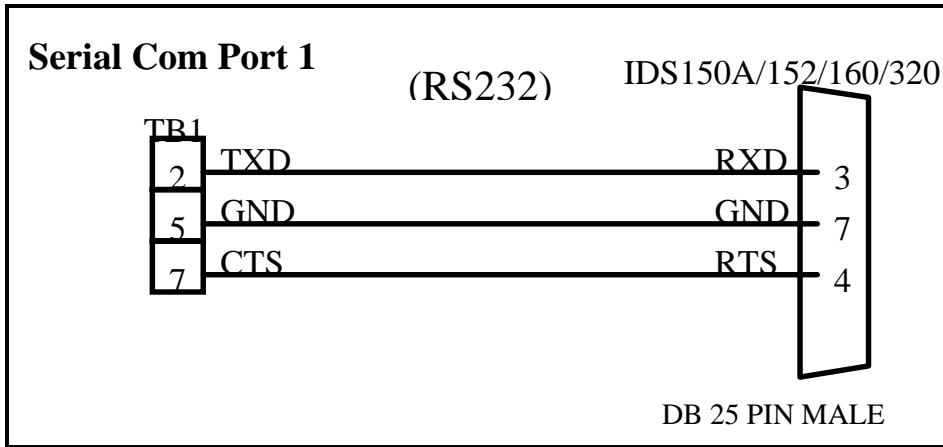

### DT210/IDS550/IDS710/PC (Continuous Output Port)

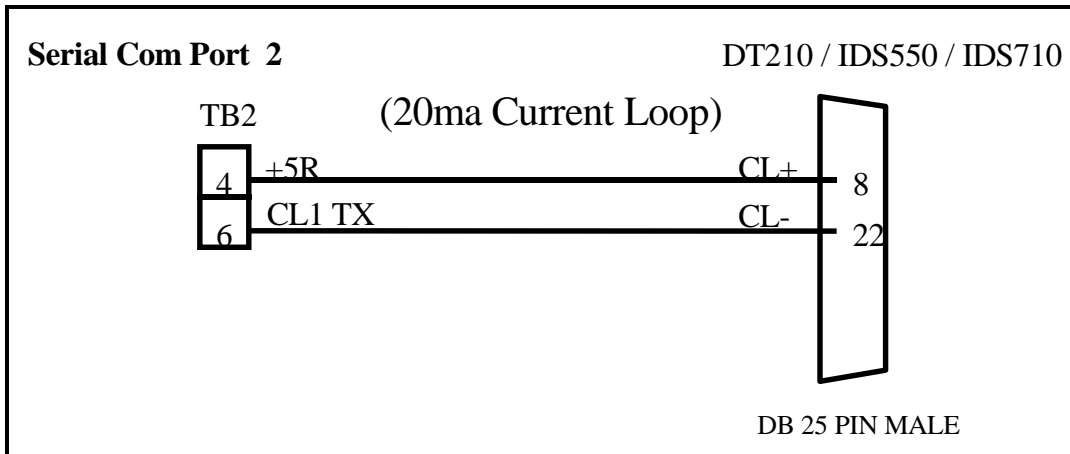
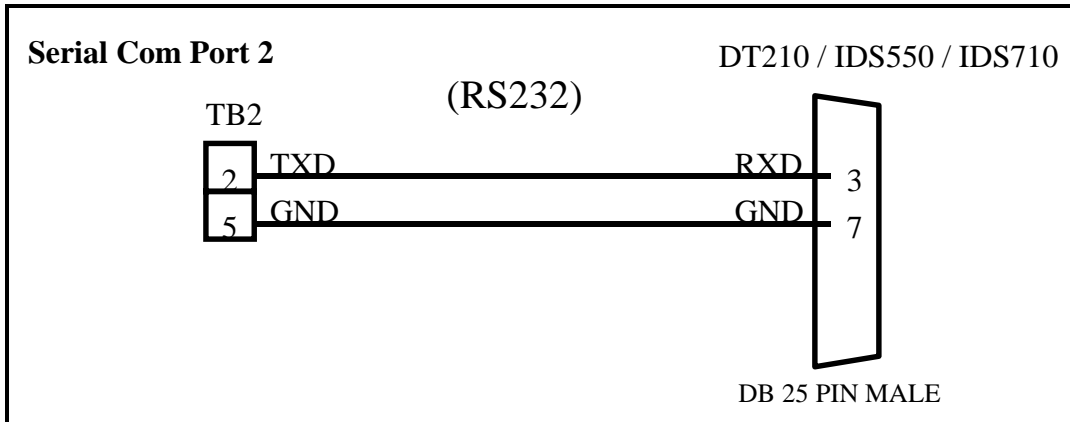

### Hewlett Packard Smart Wand HBCR-8xxx series

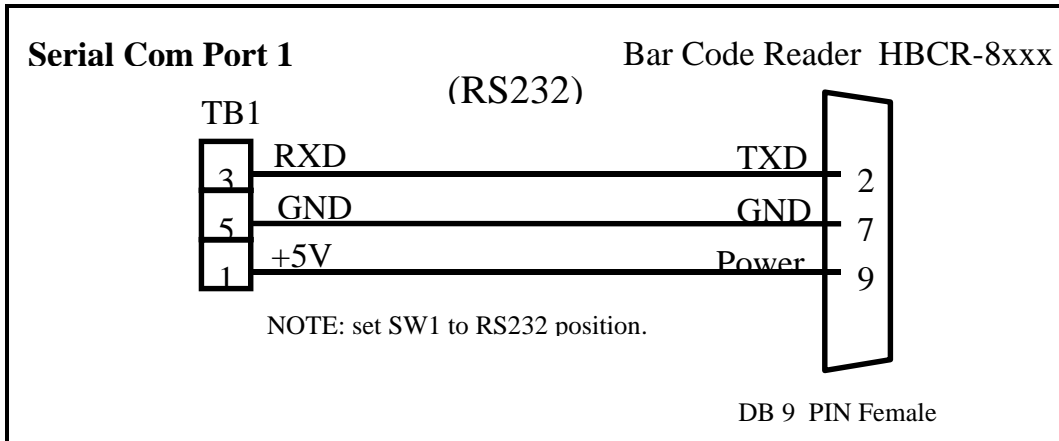

### Parallel (Centronix) Printer

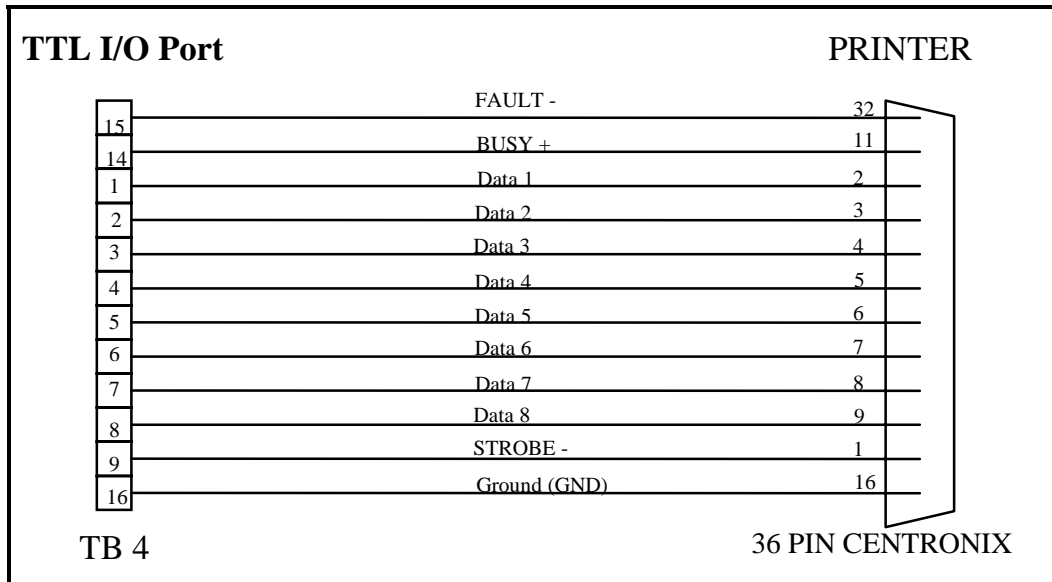

## Remote Switch Inputs

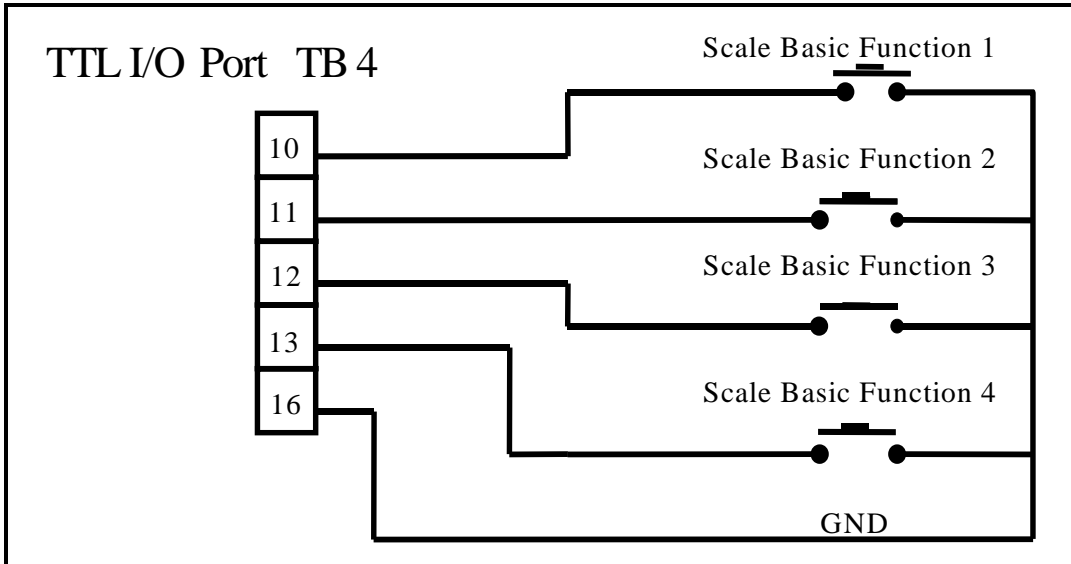

## **ANALOG OUTPUT OPTION**

### **ANALOG OUTPUT OPTION**

The Analog Output option board is internally mounted inside the indicator. The Analog Output has two jumpers; JP1 & JP2. These jumpers are used to configure the output format. Terminal block TB1 is for making external wiring connections. JP1 & JP2 are factory set for 4-20mA. Refer to the diagram below for configuration, format and alternative wiring. No interconnect cables are provided by the factory, the recommended cables used should be suitable for the conduit fittings and should comply with National Electrical code requirements.

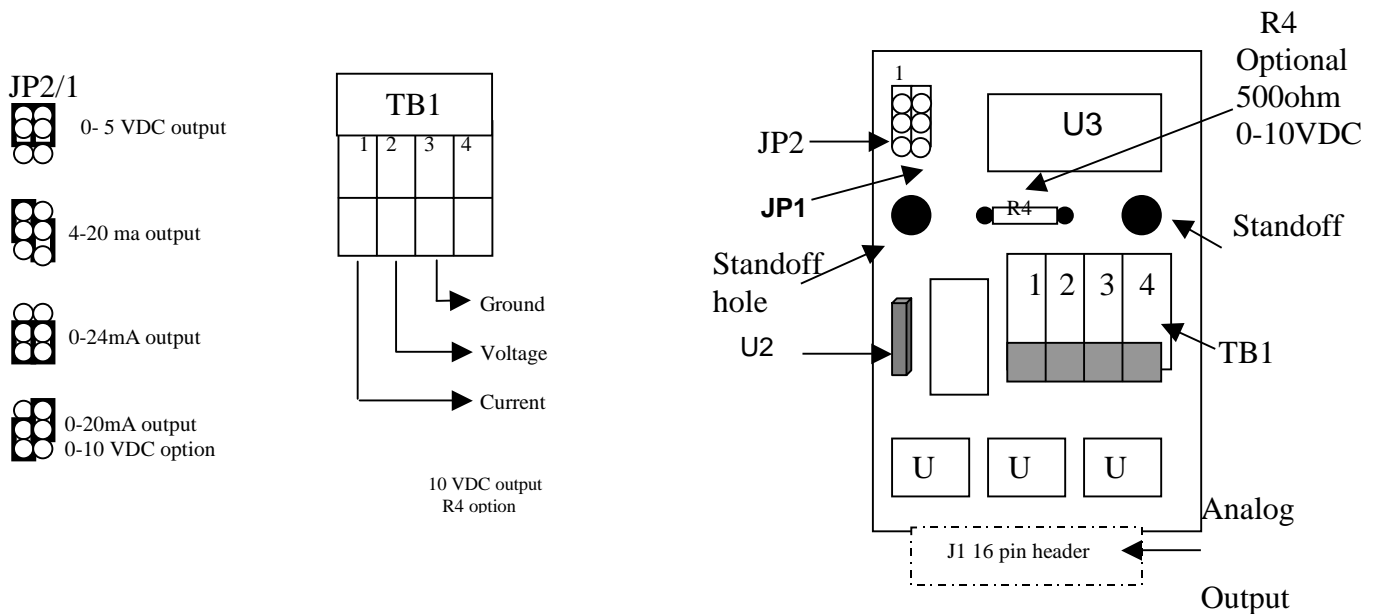

### **INSTALLATION OF ANALOG OUTPUT BOARD**

1. Before installation, remove power from the indicator and remove the back plate to access the internal board.
2. Install the (2) plastic standoffs into the holes on the CPU board and plug the analog output board (J1) onto the analog output connector marked J2 on the CPU board. Secure the analog output module to the CPU board by pushing the standoffs through the holes on the module.
3. Set JP1 and JP2 according to the desired output and connect the external device to TB1 according to the selected output.
4. Apply power to the indicator and configure parameters 81, 82, and 83 as described in the table below.

**SETUP PARAMETERS**

For proper operation, the following parameters are used to configure the operation of the analog output.

Parameter	Description	Default Value
81	Analog output span (20ma). The value entered here is the display graduations (weight/count-by) and must correspond with the full-scale digits set in parameter 17. If full scale capacity parameter 17= 10,000 then ( 0 lb's = 4mA 10,000 lb's = 20mA )	10,000 Must set to a value
82	Analog output offset (4ma). The value entered here is the display graduations (weight/count-by) and must correspond with the full-scale digits set in parameter 17.	0 (optional)
83	Analog output register/mode: 64 = Gross reg, 65 = Tare reg, 66 = Net reg (Note: Scale Basic provides other registers (1-61,43-50, 64-68) which can be set based on a mathematical formula) a register must be selected for the output to work	0 (must be set to a reg value)



# IDS440 Specifications

---

Display	1 inch x 6-digit numeric, 6 LED status indicators.
Keyboard	Sealed keyboard with tactile feel.
I/O Ports	Load Cell Interface Port. Serial port 1 - RS232 or Cur. Loop. Serial port 2 - RS232 or RS485. 9 TTL outputs. 8 TTL inputs.
Display Graduations	120,000 graduations (industrial) 10,000 hb44.
Display Increments	1, x2, x5, x10, x20, x50, x100.
Decimal Point	0 to 4 decimal places.
Internal Graduations	1,024,000.
Conversion Rate	60/sec @60hz line frequency (HS version 100/sec @ 60hz)
Signal Sensitivity	0.1 uV/graduation (min).
Signal Range	0.5 mV/V - 3.9 mV/V.
Load Cell Excitation	10 VDC.
Load Cell Current	240ma (8, 350 ohm Load Cells).
Auto Zero Tracking	0 to 60 grads, @1/4 grad increments.
Auto Zero Delay	0 to 25 sec, @0.1 sec increments.
Motion Detect	0 to 60 grads, @1/4 grad increments.
Motion Delay	0 to 25 sec, @0.1 sec increments.
Digital Filter	19 settings (0 to 18).
Digital Calibration	Front Panel - zero & span stored in EAROM.
Watchdog Timer	Fault tolerant operation (212ms).
Power Input	115/220 VAC 50/60 Hz. Only the 115VAC. Version has been tested to comply with the Underwriters Laboratories Standards for safety.
Operating Temperature	-10 to 40 degrees centigrade.
Options	Counting. Opto-22 relay modules. 12 to 28 volt DC operation. 220 VAC operation. 440HS High speed 100 samples a second. Analog output module.



# ASCII CHART

---

ASCII	DEC
Null	00
SOH	01
STX	02
ETX	03
EOT	04
ENQ	05
ACK	06
Bell	07
BS	08
HT	09
LF	10
VT	11
FF	12
CR	13
SO	14
SI	15
DLE	16
XON	17
TAPE	18
XOFF	19
DC4	20
NAK	21
SYN	22
ETB	23
CAN	24
EM	25
SUB	26
ESC	27
FS	28
GS	29
RS	30
US	31

ASCII	DEC
SP	32
!	33
"	34
#	35
\$	36
%	37
&	38
'	39
(	40
)	41
*	42
+	43
,	44
-	45
.	46
/	47
0	48
1	49
2	50
3	51
4	52
5	53
6	54
7	55
8	56
9	57
:	58
;	59
>	60
=	61
>	62
?	63

ASCII	DEC
@	64
A	65
B	66
C	67
D	68
E	69
F	70
G	71
H	72
I	73
J	74
K	75
L	76
M	77
N	78
O	79
P	80
Q	81
R	82
S	83
T	84
U	85
V	86
W	87
X	88
Y	89
Z	90
[	91
\	92
]	93
^	94
<-	95

ASCII	DEC
`	96
a	97
b	98
c	99
d	100
e	101
f	102
g	103
h	104
i	105
j	106
k	107
l	108
m	109
n	110
o	111
p	112
q	113
r	114
s	115
t	116
u	117
v	118
w	119
x	120
y	121
z	122
{	123
	124
}	125
~	126
DEL	127